

**Agilent N4376D
Lightwave Component Analyzer
User's Guide**

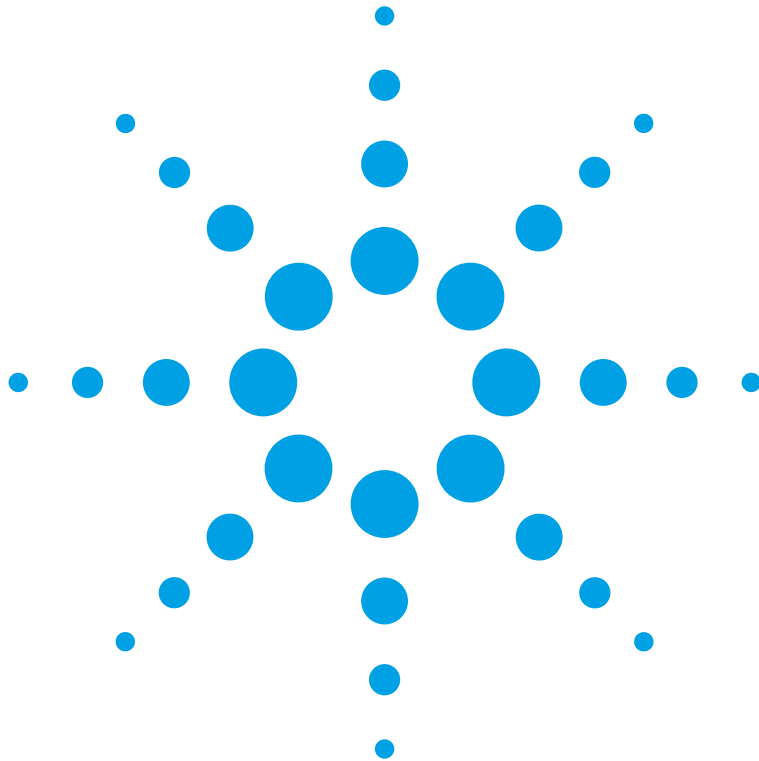

Notices

© Agilent Technologies, 2009 - 2013

No part of this manual may be reproduced in any form or by any means (including electronic storage and retrieval or translation into a foreign language) without prior agreement and written consent from Agilent Technologies, Inc. as governed by United States and international copyright laws.

Agilent Technologies, Deutschland GmbH
Herrenberger Straße 130
71034 Böblingen, Germany.

Manual part number

4376D-90B01

Edition

First Edition, August 2013

Subject matter

The material in this document is subject to change without notice.

Agilent Technologies *makes no warranty of any kind with regard to this printed material, including, but not limited to, the implied warranties of merchantability and fitness for a particular purpose.*

Agilent Technologies shall not be liable for errors contained herein or for incidental or consequential damages in connection with the furnishing, performance, or use of this material.

Printing history

New editions are complete revisions of the guide reflecting alterations in the functionality of the instrument. Updates are occasionally made to the guide between editions. The date on the title page changes when an updated guide is published. To find out the current revision of the guide, or to purchase an updated guide, contact your Agilent Technologies representative.

Warranty

This Agilent Technologies instrument product is warranted against defects in material and workmanship for a period of one year from date of shipment. During the warranty period, Agilent will, at its option, either repair or replace products that prove to be defective.

For warranty service or repair, this product must be returned to a service facility designated by Agilent. Buyer shall prepay shipping charges to Agilent and Agilent shall pay shipping charges to return the product to Buyer. However, Buyer shall pay all shipping charges, duties, and taxes for products returned to Agilent from another country.

Agilent warrants that its software and firmware designated by Agilent for use with an instrument will execute its programming instructions when properly installed on that instrument. Agilent does not warrant that the operation of the instrument, software, or firmware will be uninterrupted or error free.

Limitation of warranty

The foregoing warranty shall not apply to defects resulting from improper or inadequate maintenance by Buyer, Buyer-supplied software or interfacing, unauthorized modification or misuse, operation outside of the environmental specifications for the product, or improper site preparation or maintenance.

No other warranty is expressed or implied. Agilent Technologies specifically disclaims the implied warranties of Merchantability and Fitness for a Particular Purpose.

Exclusive remedies

The remedies provided herein are Buyer's sole and exclusive remedies. Agilent Technologies shall not be liable for any direct, indirect, special, incidental, or consequential damages whether based on contract, tort, or any other legal theory.

Assistance

Product maintenance agreements and other customer assistance agreements are available for Agilent Technologies products. For any assistance contact your nearest Agilent Technologies Sales and Service Office.

Certification

Agilent Technologies Inc. certifies that this product met its published specifications at the time of shipment from the factory.

Agilent Technologies further certifies that its calibration measurements are traceable to the United States National Institute of Standards and Technology, NIST (formerly the United States National Bureau of Standards, NBS) to the extent allowed by the Institutes' calibration facility, and to the calibration facilities of other International Standards Organization members.

ISO 9001 certification

Produced to ISO 9001 international quality system standard as part of our objective of continually increasing customer satisfaction through improved process control.

Introduction	7
<hr/>	
Documentation	8
General Safety Considerations	9
Safety symbols	9
Line power requirements	13
Optical Test Set Front and Rear Panels	16
2-port PNA version	16
4-port PNA version	19
Rear panel	22
Getting Started	23
<hr/>	
Unpacking the Lightwave Component Analyzer	24
Setting Up the Lightwave Component Analyzer	26
Using the correct connectors	27
Enabling and disabling the laser output	28
Starting the LCA	29
Accessing the User's Guide	29
Performance Quick Check	31
<hr/>	
Preparation	32
Network analyzer settings and electrical calibration	32
Verifying your Electrical Calibration	33
Verifying the Optical Connections and Optical CW Operation	34
Verifying the Electrical Connection and Electro-optical Operation	37
Measurement Concepts	41
<hr/>	
General Measurement Techniques and Considerations	42
EO measurements (lasers, modulators)	44
OE measurements (photodiodes)	45
OO measurements	45
Signal Relationships in Opto-electric Devices	46
Single-Ended Measurements	50

Differential Measurements	50
Differential OE measurements	52
Differential EO measurements	52
Differential results	52
Calibration Concept	53
Measuring 75 Ohm devices	55
Triggering Concepts	56
User Interface Reference	57
<hr/>	
The LCA Function Keys	58
Default and Advanced Measurement Parameters	60
Saving and Loading Setups	60
Saving setups	60
Loading setups	62
The Measurement Parameters	62
Measure Mode	62
LCA System Settings	63
Optical Path Deembedding	65
RF Path Deembedding	66
Tools	67
Laser Source	68
Receiver	68
RF Power	68
RF Switches	69
Reset UI	70
Making Measurements	71
<hr/>	
Starting the Lightwave Component Analyzer	72
Calibrating the Network Analyzer before Measurements	72
Measuring Opto-Electrical (OE) Devices	81
Initializing the OE measurement	82
Making single-ended OE measurements	89
Making differential OE measurements	89

Measuring Electro-Optical (EO) Devices	90
Initializing the EO measurement	91
Making single-ended EO measurements	93
Making differential EO measurements	94
Returning to Electrical Measurements	94
Measuring Optical-Optical (OO) Devices	95
Initializing the OO measurement	96
Making OO measurements	101
Measuring Optical Power	101
Maintenance	103
<hr/>	
Cleaning	104
Safety precautions	104
Why is it important to clean optical devices?	105
What do I need for proper cleaning?	105
Preserving connectors	110
Cleaning instrument housings	111
Which cleaning procedure should I use for optical components and connectors?	111
Replacing the Fuse	119
Troubleshooting	121
<hr/>	
Checking the Operation of the Lightwave Component Analyzer	122
Event Log	122
Reinstalling and Updating the Software	123
<hr/>	
Backing Up your LCA Data	124
Reinstalling the LCA Software	124
Updating the LCA software	124
Reinstalling the LCA software	125
Definition of Terms	127
<hr/>	
Definition of Terms	128

Specifications	135
<hr/>	
Definitions	136
Specifications (guaranteed).....	136
Typical Values (characteristics).....	136
General Characteristics	136
Explanation of Terms.....	137
Responsivity	137
Relative Frequency Response Uncertainty	137
Absolute Frequency Response Uncertainty	137
Frequency Response Repeatability.....	137
Minimum Measurable Frequency Response.....	137
Definition of LCA Input and Output Names.....	138
Agilent N4376D Specifications	138
Transmitter and Receiver Specifications	140
Specifications for Electrical-Electrical Measurements (E/E Mode)	141
Specifications for Electro-Optical Measurements at 850 nm (E/O Mode).....	142
Specifications for Optical-Electrical Measurements at 850 nm (O/E Mode).....	143
Specifications for optical to optical measurements at 850 nm (O/O mode)	144
General Characteristics	145
General Characteristics (continued).....	146
Regulatory and Warranty Information	151
<hr/>	
Regulatory Information	152
Declaration of Conformity	153
Warranty	154
System.....	154
Remove all doubt.....	154
Phone or Fax.....	156
Agilent Online Information:	157
Ordering Information	159
<hr/>	
Index	163
<hr/>	

1

Introduction

Documentation	8
General Safety Considerations.....	9
Optical Test Set Front and Rear Panels.....	16

Documentation

The documentation for the Agilent N4376D Lightwave Component Analyzer consists of

- The documentation for the Agilent network analyzer. This documentation is on the hard disk of the network analyzer. Refer to it for using the network analyzer for electrical to electrical measurements, or for the configuration of the network analyzer.
- The documentation for the optical test set and the Lightwave Component Analyzer application. Refer to this documentation for information on using the optical test set, together with the network analyzer, for optical to optical, electrical to optical and optical to electrical measurements, or for setting up your lightwave component analyzer.

General Safety Considerations

This product has been designed and tested in accordance with the standards listed on the manufacturer's Declaration of Conformity, and has been supplied in a safe condition. The documentation contains information and warnings that must be followed by the user to ensure safe operation and to maintain the product in a safe condition.

Safety symbols

CAUTION

The *caution* sign denotes a hazard. It calls attention to a procedure which, if not correctly performed or adhered to, could result in damage to or destruction of the product. Do not proceed beyond a caution sign until the indicated conditions are fully understood and met.

WARNING

The *warning* sign denotes a hazard. It calls attention to a **procedure which, if not correctly performed or adhered to, could result in injury or loss of life. Do not proceed beyond a warning sign until the indicated conditions are fully understood and met.**

Instrument markings



The instruction manual symbol. The product is marked with this warning symbol when it is necessary for the user to refer to the instructions in the manual.



The laser radiation symbol. This warning symbol is marked on products which have a laser output.



The Off-On symbols are used to mark the positions of the instrument power operating switch.



The recycling symbol indicates the general ease with which the instrument can be recycled.



N10149

The C-Tick mark is the certification mark of the Australian Communications Authority.



ICES/NMB-001
ISM GRP 1-A

The CE mark is the conformity marking of the European Community.



LR 53538 C

The CSA mark is a the certification mark of the Canadian Standards Association.

WARNING

If this product is not used as specified, the protection provided by the equipment could be impaired. This product must be used in a normal condition (in which all means for protection are intact) only.

WARNING

No operator serviceable parts inside. Refer servicing to qualified service personnel. To prevent electrical shock do not remove covers.

WARNING

This is a Safety Class 1 Product (provided with protective earth). The mains plug shall only be inserted in a socket outlet provided with a protective earth contact. Any interruption of the protective conductor inside or outside of the instrument is likely to make the instrument dangerous. Intentional interruption is prohibited.

WARNING

To prevent electrical shock, disconnect the instrument from mains before cleaning. Use a dry cloth or one slightly dampened with water to clean the external case parts. Do not attempt to clean internally.

WARNING

Using controls or adjustments or performing procedures other than those specified in the documentation supplied with your equipment can result in hazardous radiation exposure.

CAUTION

This product complies with overvoltage Category II and Pollution Degree 2.

CAUTION

Ventilation requirements: When installing the product in a cabinet, the convection into and out of the product must not be restricted. The ambient temperature (outside the cabinet) must be less than the maximum operating temperature of the product by 4 °C for every 100 watts dissipated in the cabinet. If the total power dissipated in the cabinet is greater than 800 watts, then forced convection must be used.

CAUTION

Install the instrument so that the power switch is readily identifiable and is easily reached by the operator. This is the instrument disconnecting device. It disconnects the mains circuit from the mains supply before other parts of the instrument. Alternatively, an externally installed switch or circuit breaker (which is readily identifiable and is easily reached by the operator) may be used as a disconnecting device.

CAUTION

Always use the three-prong AC power cord supplied with this instrument. Failure to ensure adequate earth grounding by not using this cord may cause instrument damage.

CAUTION

This instrument has autoranging line voltage input. Be sure the supply voltage is within the specified range.

Initial safety information

The laser source used in the Lightwave Component Analyzer is classified as Class 1M according to IEC 60825-1/2007. All laser sources comply with 21 CFR 1040.10 except for deviations pursuant to Laser Notice No. 50, dated 2007-06-24.

Laser Safety

Laser class 1M label

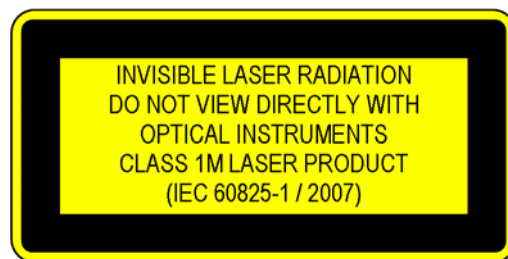

Figure 1 Class 1M Safety Label

A sheet of laser safety labels is included. In order to meet the requirements of IEC 60825-1 we recommend that you stick the laser safety labels, in your language, onto a suitable location on the outside of the instrument where they are clearly visible to anyone using the instrument

	N4376D
Laser wavelength range	850 ± 10 nm
Laser Type	DFB
Laser Class according to IEC 60825-1	1M
Maximum CW output power of LCA ^a	< 4 mW
Maximum permissible CW output power	5.3 mW
Numerical aperture	0.15
Beam waist diameter	< 50 µm

^a CW output power is defined as the highest possible optical output power that the laser source can produce at the output connector

WARNING

Please pay attention to the following laser safety warnings:

- Under no circumstances look into the end of an optical cable attached to the optical output when the device is operational. The laser radiation can seriously damage your eyesight.
 - Do not enable the laser when there is no fiber attached to the optical output connector.
 - The laser is enabled by the software or by pressing the laser switch on the front panel. The laser is on when the green LED above the switch is lit.
 - The use of the instruments, such as microscopes or spectacles, with this product will increase the hazard to your eyes.
 - The laser module has built-in safety circuitry which will disable the optical output in the case of a fault condition.
 - Refer servicing *only* to qualified and authorized personnel.
-

Line power requirements

CAUTION

The Agilent N4376D Lightwave Component Analyzer complies with overvoltage category II and can operate from the single-phase AC power source that supplies between 100 V and 240 V at a frequency in the range 50 to 60 Hz. The maximum power consumption of the optical test set is 40 VA with all options installed.

Please refer to the documentation for your network analyzer for information on its line power requirements.

Line power connectors

In accordance with international safety standards, the instrument has a three-wire power cable. When connected to an appropriate AC power receptacle, this cable earths the instrument cabinet. The type of power cable shipped with each instrument depends on the country of destination. Please refer to “Power Cords” on page 167 for the part numbers of available power cables.

WARNING

To avoid the possibility of injury or death, you must observe the following precautions before switching on the instrument.

- **Insert the power cable plug only into a socket outlet provided with a protective earth contact. Do not use an extension cord without a protective conductor. Using an extension cord without a protective conductor means the instrument is not earthed.**
- **Do not interrupt the protective earth connection intentionally.**
- **Do not remove protective covers. Operating personnel must not remove instrument covers. Component replacement and internal adjustments must be made only by qualified service personnel.**
- **Instruments that appear damaged or defective should be made inoperative and secured against unintended operation until they can be repaired by qualified service personnel.**
- **Defective, damaged, or malfunctioning instruments must be returned to an Agilent Technologies Service Center.**

Do not operate the instrument in the presence of flammable gases or fumes. Operation of any electrical instrument in such an environment constitutes a definite safety hazard.

Environmental information

This product is intended for indoor use only.

This product complies with the WEEE Directive (2002/96/EC) marking requirements. The affixed label indicates that you must not discard this electrical/electronic product in domestic household waste.

Product Category: With reference to the equipment types in the WEEE Directive Annex I, this product is classed as a "Monitoring and Control instrumentation" product.



Do not dispose in domestic household waste.

To return unwanted products, contact your local Agilent office, or see www.agilent.com/environment/product/ for more information.

Optical Test Set Front and Rear Panels

2-port PNA version

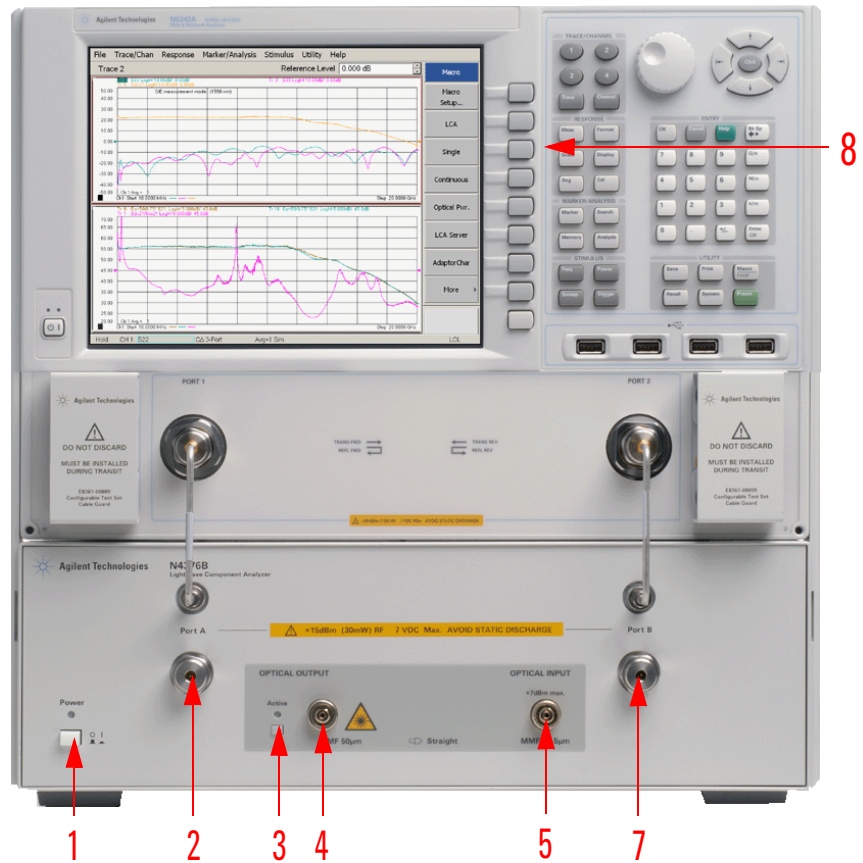







Figure 1 Front Panel (-312)

For further information on the front panel of the network analyzer, please refer to the documentation supplied with the network analyzer.

1	Power switch	Turns on the optical test set. To turn on the PNA, press the PNA's power key.
2	Port A	<p>Caution: Be sure you do not exceed the RF power values and DC levels noted on the front panel of the instrument.</p> <p>This is the RF port used for electrical calibration and to connect to E/O or E/E device.</p>
3	Laser switch	<p>Press the switch to turn the laser on (LED on), and off (LED off).</p> <p>The laser can also be switched on and off from the LCA Measurement Setup Macro (in the LCA System Settings menu), or remotely.</p> <p>This switch overrides other. Pressing this switch during a measurement, will invalidate your results.</p>
4	Optical Output	<p>Warning: Laser Radiation can damage your eyesight! Refer to "Laser Safety" on page 12 for safety instructions.</p> <p>This is the output of the optical transmitter of the lightwave component analyzer.</p>
5	Optical Input 1 (low power)	<p>Caution: Do not apply more than +3 dBm (maximum safe average input power).</p> <p>This input is the standard optical input to the optical test set for optical powers up to 0 dBm.</p>

7	Port B	This is the RF port used for electrical calibration and to connect to O/E and E/E devices.
8	Function keys	<p>Used to control the Lightwave Component Analyzer.</p> <p>Press the [Macro/Local] Utility button on the network analyzer to display the LCA function keys.</p> <ul style="list-style-type: none"> •  : Setup an LCA Measurement •  : Perform a single sweep measurement with the current measurement setup •  : Perform continuous sweep measurements with the current measurement setup •  : Start the optical power meter •  : Start the LCA server (if not already running)

4-port PNA version

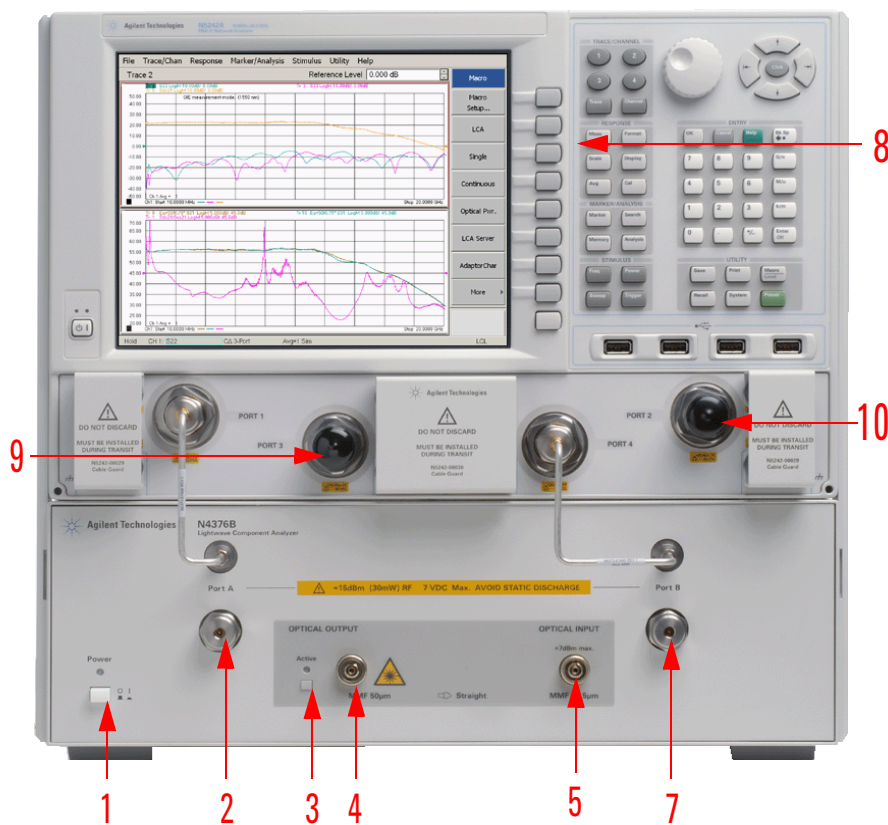







Figure 2 Front Panel for 4-port PNA (Options 42x)

For further information on the front panel of the network analyzer, please refer to the documentation supplied with the network analyzer.

1	Power switch	Turns on the optical test set. To turn on the PNA, press the PNA's power key.
2	Port A	<p>Caution: Be sure you do not exceed the RF power values and DC levels noted on the front panel of the instrument.</p> <p>This is the RF port used for electrical calibration and to connect to single-ended or differential E/O or E/E device.</p>

<p>3</p>	<p>Laser switch</p>	<p>Press the switch to turn the laser on (LED on), and off (LED off).</p> <p>The laser can also be switched on and off from the LCA Measurement Setup Macro (in the LCA System Settings menu), or remotely.</p> <p>This switch overrides other. Pressing this switch during a measurement, will invalidate your results.</p>
<p>4</p>	<p>Optical Output</p>	<p>Warning: Laser Radiation can damage your eyesight! Refer to “Laser Safety” on page 12 for safety instructions.</p> <p>This is the output of the optical transmitter of the lightwave component analyzer.</p>
<p>5</p>	<p>Optical Input 1 (low power)</p>	<p>Caution: Do not apply more than +3 dBm (maximum safe average input power).</p> <p>This input is the standard optical input to the optical test set for optical powers up to 0 dBm.</p>
<p>7</p>	<p>Port B</p>	<p>This is the RF port used for electrical calibration and to connect to single-ended and differential O/E and E/E devices.</p>

8	Function keys	<p>Used to control the Lightwave Component Analyzer.</p> <p>Press the [Macro/Local] Utility button on the network analyzer to display the LCA function keys.</p> <ul style="list-style-type: none"> •  : Setup an LCA Measurement •  : Perform a single sweep measurement with the current measurement setup •  : Perform continuous sweep measurements with the current measurement setup •  : Start the optical power meter •  : Start the LCA server (if not already running)
9	Network analyzer Port 3	<p>This is an S parameter measurement port of the Network analyzer.</p> <p>This is the RF port used for electrical calibration and to connect to differential EO, OE and EE devices.</p>
10	Network analyzer Port 2	<p>This is an S parameter measurement port of the Network analyzer.</p> <p>This is the RF port used for electrical calibration and to connect to differential EO, OE and EE devices.</p>

Rear panel

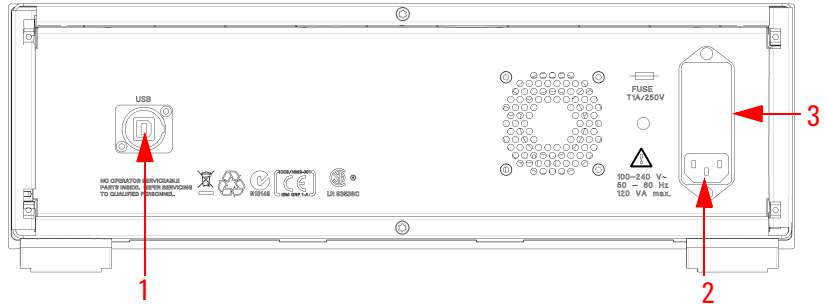

Figure 3 Rear Panel

For information on the rear panel of the network analyzer, please refer to the documentation supplied with the network analyzer.

1	USB	The software on the network analyzer uses the USB port to control the optical test set.
2	Line power cable connector	Plug in your power cable here.
3	Line fuse	Replace only with same type.

2

Getting Started

Unpacking the Lightwave Component Analyzer	24
Setting Up the Lightwave Component Analyzer	26

Unpacking the Lightwave Component Analyzer

Unpack your shipment.

- Inspect the shipping containers for damage.
- Inspect the instruments.
- Verify that you received the options and accessories that you ordered.

Keep the shipping containers and cushioning material until you have inspected the contents of the shipment for completeness and have checked the equipment mechanically and electrically.

The shipment should contain

- 1x Network-analyzer depending on option selected
- 1x N4376D optical test set
- 2x 81000NI optical adapter
- 1x 4376D-90A01 Getting started
- 1x 4373B-90CD1 LCA support CD
- 1x 1150-7896 Keyboard
- 1x 1150-7799 Mouse
- 1x 8121-1242 USB cable
- 1x E5525-10285 UK6 report
- 1x N4373-61627 electrical short cut cable
- 1x 9320-6677 RoHS addendum for Photonic T&M accessories
- 1x 9320-6654 RoHS addendum for Photonic T&M products

Additional, option dependent shipping contents:

- Options 4xx (4-port PNAs):
 - 1x N4373-61604 0.5 m (m) to (f) high performance RF cable
- Options 2xx (2-port PNAs):
 - 2x N4373-61604 0.5 m (m) to (f) high performance RF cable
- -023 2x LC 50 μ m to FC/APC 0.5 m patch cord
- -024 2x LC 62.5 μ m to FC/APC 0.5 m patch cord
- -025 2x SC 50 μ m to FC/APC 0.5 m patch cord
- -026 2x SC 62.5 μ m to FC/APC 0.5 m patch cord

Network analyzer options:

- Option 220:
 - 26.5 GHz, 2 ports, single source PNA (N5222A-200) and RF cables
- Option 221:
 - 26.5 GHz, 2 ports, single source PNA (N5222A-201) with configurable test set and RF cables
- Option 222:
 - 26.5 GHz, 2 ports, single source PNA (N5222A-219) with configurable test set, extended power range, bias-tees, and RF cables
- Option 420:
 - 26.5 GHz, 4 ports, dual source PNA (N5222A-400) and RF cables
- Option 421:
 - 26.5 GHz, 4 ports, dual source PNA (N5222A-401) with configurable test set and RF cables
- Option 422:
 - 26.5 GHz, 4 ports, dual source PNA (N5222A-419) with configurable test set, extended power range, bias-tees, and RF cables
- Option 229:
 - Integration of customer's 26.5 GHz, 2 port PNA (N5222A or N5242A) with any configuration and RF cables
- Option 249:
 - Integration of customer's 26.5 GHz, 4 port PNA (N5222A or N5242A) with any configuration and RF cables

If anything is missing or defective, contact your nearest Agilent Technologies sales office. If the shipment was damaged, contact the carrier, then contact the nearest Agilent Technologies sales office.

Setting Up the Lightwave Component Analyzer

CAUTION

The network analyzer and Lightwave Component Analyzer module are assembled as one analyzer unit. Lifting this instrument requires two people using proper lifting techniques. For the combined weight, please consult the specifications in the User's Guide and the user's documentation for the network analyzer.

1. Unpack and inspect the contents as described in "Unpacking the Lightwave Component Analyzer" on page 24.
2. Remove the dust cap from the Optical Output.

CAUTION

If you are using a patchcord with a straight and angled connectors, make sure you only connect the angled connector (green) to the optical test set.

3. Remove the dust cap from the optical patchcord.
4. Connect the optical patchcord.
5. Repeat step 2. to step 4. for the optical input.

CAUTION

Always use patchcords to connect to your DUT. This protects the connectors of the optical test set, by minimizing the number of connector changes.

CAUTION

The contact connector on the optical test set is angled. If you are using a patchcord with straight (red) and angled (green) connectors, make sure you connect the angled connector to the optical test set. Connecting to the optical test set with a straight connector will damage it.

CAUTION

Before you connect any fiber-optic cable to the Lightwave Component Analyzer, please ensure it has been properly cleaned. Fiber-optic connectors are easily damaged when connected to dirty or damaged cables and accessories. When you use improper cleaning and handling techniques, you risk expensive instrument repairs, damaged cables, and compromised measurements.

6. On the rear, using the USB cable supplied, connect the network analyzer to the optical test set.
7. Connect the power cables..

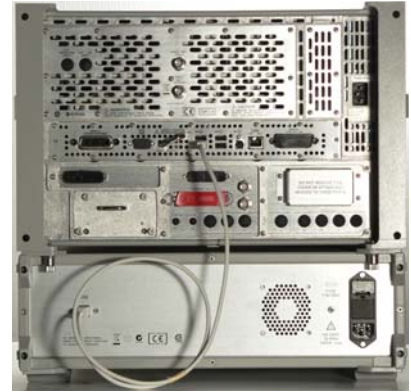
**NOTE**

We recommend you backup your LCA data regularly.

Please refer to the user guide for information on the files to backup.

Using the correct connectors

CAUTION

Always use patchcords to connect to your DUT. This protects the connectors of the optical test set, by minimizing the number of connector changes.

CAUTION

The contact connector on the optical test set is angled. If you are using a patchcord with straight (red) and angled (green) connectors, make sure you connect the angled connector to the optical test set. Connecting to the optical test set with a straight connector will damage it.

CAUTION

Before you connect any fiber-optic cable to the Lightwave Component Analyzer, please ensure it has been properly cleaned. Fiber-optic connectors are easily damaged when connected to dirty or damaged cables and accessories. When you use improper cleaning and handling techniques, you risk expensive instrument repairs, damaged cables, and compromised measurements.

The optical input and output of the Agilent N4376D Lightwave Component Analyzer use angled connectors. Depending on the option you ordered, you will also have received two patchcords with an angled and a straight connector.

- option 023 includes 50 μm patchcords with an angled and an LC connector
- option 024 includes 62.5 μm patchcords with an angled and an LC connector
- option 025 includes 50 μm patchcords with an angled and an SC connector
- option 026 includes 62.5 μm patchcords with an angled and an SC connector

Using the patchcord ensures the best “ripple” performance (lowest ripple) for your measurements. Two or more, straight connector interfaces in the optical measurement path can cause optical cavities. These result in frequency dependent interference effects (ripple), which may significantly degrade the performance of the LCA. This may impact user calibrations in OE and OO measurements. We recommend you use the patchcords supplied to minimize the number of straight connections.

Using the patchcords also keeps service costs down, as the adaptor patchcord can be exchanged easily.

Angled contact connectors have up to 30 dB higher return loss than straight connectors, and we recommend them for best performance results. With angled fiber endfaces, reflected light tends to reflect into the cladding, reducing the amount of light that reflects back to the source.

Enabling and disabling the laser output

You can switch the Laser on and off by pressing the button besides the Optical Output.

After the LCA application running on the network analyzer has initialized it, the green LED besides the laser output indicates whether the laser is emitting radiation. If the Laser output is on, the green LED on the front panel of the module is lit. If the Laser output is off, the green LED on the front panel of the module is unlit.

NOTE

This button overrides the internal laser ON/OFF settings. Pressing this button during a measurement will cause errors in the results.

Starting the LCA

1. If it is not already running, start the LCA server by pressing , or by clicking the LCA server icon on the desktop.

If the LCA server is running, but the function keys are not displayed, press the [Macro/Local] Utility key until they appear.

2. Press .

You can now proceed with setting up measurement. For further information on measurements refer to Chapter 5 and Chapter 6.

Accessing the User's Guide

1. If it is not already started, start the LCA as described above.
2. Press  in the LCA user interface to get to the electronic Version of the users guide.

Getting Started

3

Performance Quick Check

Preparation	32
Verifying your Electrical Calibration	33
Verifying the Optical Connections and Optical CW Operation	34
Verifying the Electrical Connection and Electro-optical Operation	37

This chapter shows how to

- Verify the optical and electrical connections to the N4376D Lightwave Component Analyzer
- Verify the performance of your N4376D Lightwave Component Analyzer
- Trouble shoot, if you think there may be a malfunction
- Perform an acceptance test

Preparation

1. Turn on the network analyzer and the optical test set.
2. Allow the optical test set and the network analyzer to warm up (please refer to “Explanation of Terms” on page 137 for the warm up time).
3. If it is not already started, start the network analyzer application.
Consult the documentation supplied with the network analyzer if you need help with this step.

NOTE

Most performance problems are caused by damaged or dirty electrical or optical connectors.

Before starting the performance verification procedure make sure all electrical and optical connectors are in excellent condition.

For more information on cleaning procedures see “Cleaning” on page 104 for information on cleaning optical connections, and to the user guide of the network analyzer for information on cleaning electrical connections.

Network analyzer settings and electrical calibration

1. On the network analyzer make the following settings:
 - Start Frequency: 10 MHz, Stop Frequency: 26.5 GHz
 - Number of points: 2650
 - IF bandwidth: 300 Hz
 - Select “Reduce IF BW at Low Frequencies”.
 - Averages: 1
 - RF output power: -10 dBm
2. Select “Stepped sweep - sweep moves in discrete steps”.

3. Calibrate the network analyzer electrically.
 - a. Make sure the LCA has been returned to the electrical measurement mode as described in “Returning to Electrical Measurements” on page 94.

NOTE



To meet the technical specifications, you must use the electronic calibration module.

- b. Proceed with the electrical calibration as described in “Electrical calibration for “User Calibration” and OO measurements” on page 73.

We recommend you use “Electronic Calibration Modules” for calibrating the Network Analyzer. For more information on handling using and maintaining “Electronic Calibration Modules”, please refer to the “Reference Guide Agilent Technologies Electronic Calibration Modules”, available on the Agilent website.

Verifying your Electrical Calibration

Passing this test ensures that the electrical calibration is within expected performance.

1. Follow the steps in the sections “Preparation ” on page 32 and “Network analyzer settings and electrical calibration” on page 32.
2. Connect the N4373-61627 “3.5 f to 3.5 f mm RF-Cable” supplied between Port A and Port B of the optical test set.
3. Press the [Macro/Local utility button until you see .
4. Click  to start the LCA measurement setup.
5. Select the EE Measurement tab.
6. Click .
7. Make a corrected measurement with the network analyzer.

8. Inspect the results.

- Electrical return loss S11 should be similar to S22 (S44 for 4-port PNA).
- Both curves should be below -17dB over the full measurement range, with only low frequency dependence on applied modulation frequency.
- Transmission loss S12 should be similar to S21 (S14 should be similar to S41 for 4-port PNA).
- Both curves should be within +0.1dB to -0.9 dB over the full measurement range, with only low frequency dependence on applied modulation frequency.

If the results differ from the expected values

- Visually inspect the electrical connectors on the “Electronic Calibration Modules” and the “Flexible Cables for Test Ports” optical test set.
If an electrical connector seems to be damaged, contact Agilent for repair or replacement.
- Clean the electrical connectors on the Electronic Calibration Modules and on the Optical test Set.
Refer to the “Connector Care” section in the User’s Guide for the network analyzer if you need information on cleaning and inspection of RF connectors

Perform a new electrical calibration and retest.

If the problem persists contact Agilent for support.

Verifying the Optical Connections and Optical CW Operation

Passing these tests ensures that the transmitter and receiver are within expected optical CW performance.

1. Follow the steps in the sections “Preparation ” on page 32 and “Network analyzer settings and electrical calibration” on page 32.
2. If you have option -023:
Making sure the angled connector connects to the optical test set, connect the two straight-angled optical patchcords (N4376D-023) to the optical output and input 1 (“+3 dBm”).
Use the LC/LC adapter (0960-2819) to connect the straight ends of the optical patchcords together.

If you have option -024:

Making sure the angled connector connects to the optical test set, connect the two straight-angled optical patchcords (N4376D-024) to the optical output and input 1 (“+3 dBm”).

Use the LC/LC adapter (0960-2819) to connect the straight ends of the optical patchcords together.

If you have option -025:



Making sure the angled connector connects to the optical test set, connect the two straight-angled optical patchcords (N4376D-025) to the optical output and input 1 (“+3 dBm”).

Use the SC/SC adapter (1005-1264) to connect the straight ends of the optical patchcords together.



If you have option -026:

Making sure the angled connector connects to the optical test set, connect the two straight-angled optical patchcords (N4376D-026) to the optical output and input 1 (“+3 dBm”).

Use the SC/SC adapter (1005-1264) to connect the straight ends of the optical patchcords together.

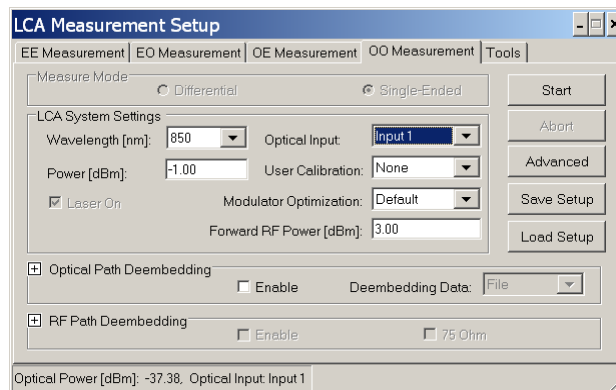
3. Press the [Macro/Local utility button until you see .
4. Press  to start the LCA measurement setup.
5. Select the OO measurement tab.



6. Set the following parameters:
 - Laser power: -1 dBm
 - Optical input: Input 1
 - User Calibration: None
7. Click , then  to set the output power.

8. Press  to start optical power meter application.

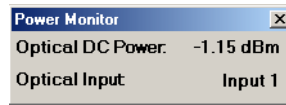

9. Read the optical power from the power meter application.

The readout must be -1 dBm \pm 0.5 dB

10. Press the [Macro/Local utility button until you see



11. Press  to start the LCA measurement setup.

12. Select the OO measurement tab.

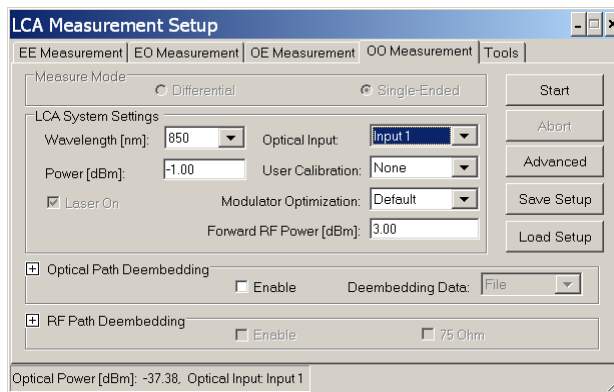

13. Set the following parameters:

- Laser power: -5 dBm
- Optical input: input1 (“+3 dBm max”).
- User Calibration: None

14. Click , then  to set the output power.

15. Press  to start optical power meter application

16. Read the optical power from the power meter application.

The readout must be -5 dBm \pm 0.5 dB

If the results differ from the expected

- Try cleaning the optical connections as described in “Cleaning” on page 104.
- Switch the laser off and inspect all optical connectors with a microscope.
 - If the connectors on the N4376D Lightwave Component Analyzer seem to be damaged contact Agilent for repair.

- If the connectors on the patchcord seem to be damaged contact Agilent for replacements.
- With an external optical power meter, you can verify the output power of the internal laser and the optical connection on the transmitter side.

If the problem persists contact Agilent for support.

Verifying the Electrical Connection and Electro-optical Operation

Passing these tests ensures that the internal transmitter and receiver of the Lightwave Component Analyzer are within expected electro-optical performance.

1. Follow the steps in the sections “Preparation ” on page 32 and “Network analyzer settings and electrical calibration” on page 32.
2. On the network analyzer make the following settings:
 - IF bandwidth: 100 Hz
 - Select “Reduce IF BW at Low Frequencies”.
3. If you have option -023:
 Making sure the angled connector connects to the optical test set, connect the two straight-angled optical patchcords (N4376D-023) to the optical output and input 1 (“+3 dBm”).
 Use the LC/LC adapter (0960-2819) to connect the straight ends of the optical patchcords together.

If you have option -024:

Making sure the angled connector connects to the optical test set, connect the two straight-angled optical patchcords (N4376D-024) to the optical output and input 1 (“+3 dBm”).

Use the LC/LC adapter (0960-2819) to connect the straight ends of the optical patchcords together.

If you have option -025:



Making sure the angled connector connects to the optical test set, connect the two straight-angled optical patchcords (N4376D-025) to the optical output and input 1 (“+3 dBm”).

Use the SC/SC adapter (1005-1264) to connect the straight ends of the optical patchcords together.

If you have option -026:

Making sure the angled connector connects to the optical test set, connect the two straight-angled optical patchcords (N4376D-026) to the optical output and input 1 (“+3 dBm”).

Use the SC/SC adapter (1005-1264) to connect the straight ends of the optical patchcords together.

4. Press the [Macro/Local utility button until you see .
5. Press  to start the LCA measurement setup.
6. Select the OO measurement tab.

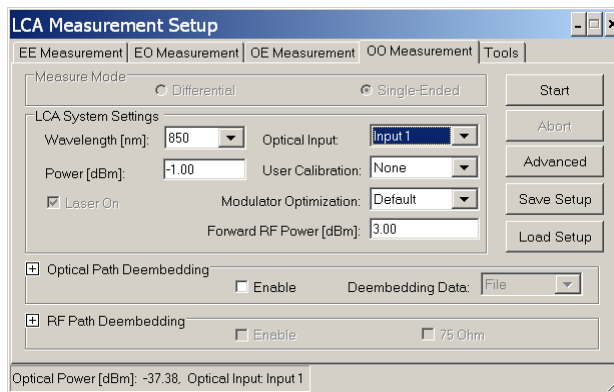

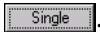
7. Set the following parameters:
 - Laser power: -1 dBm
 - Optical input: input1 (“+3 dBm max”)
 - User Calibration: None
 - Modulator optimization: Continuous
 - Forward RF Power: +3 dBm
8. Click , then .

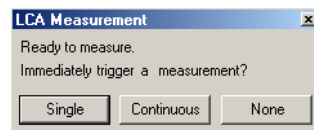

9. Right click the measurement trace, and select “Autoscale All” in the context menu.

At the end of the measurement, there should be a flat trace.

- An ideal trace might look like this.
- Though please note that this trace is also within specifications.
- If there are problems with the electrical calibration of the network analyzer - particularly if the wrong calibration planes have been used - the trace may look like this, with high frequency ripples.

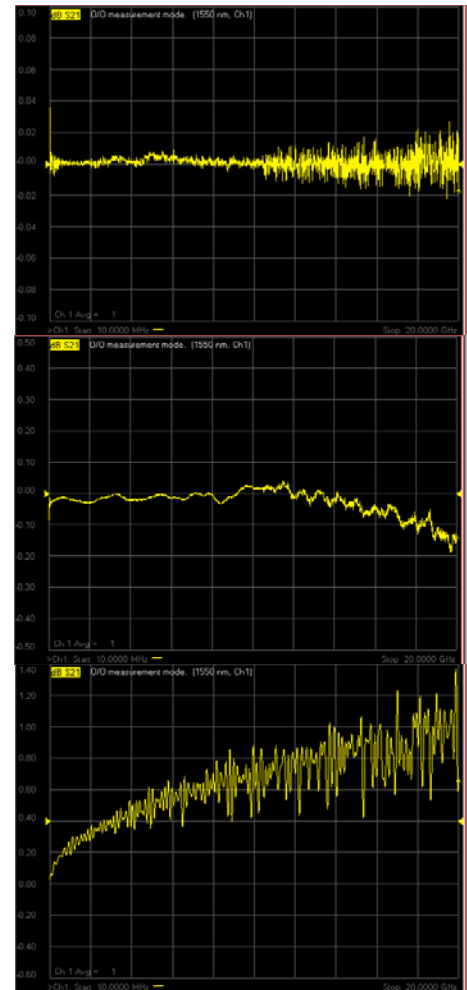

If the results differ from the expected values

- Inspect the electrical connectors on the N4376D Lightwave Component Analyzer. If electrical connectors seems to be damaged contact Agilent for repair or replacement.
- Clean the electrical connectors on the N4376D Lightwave Component Analyzer.

Perform a new electrical calibration and retest.

If the problem persists, contact Agilent for support.

Performance Quick Check

4

Measurement Concepts

General Measurement Techniques and Considerations .	42
Signal Relationships in Opto-electric Devices	46
Single-Ended Measurements	50
Differential Measurements	50
Calibration Concept	53
Measuring 75 Ohm devices	55
Triggering Concepts	56

General Measurement Techniques and Considerations

The concept of lightwave component analysis is straightforward. Measurements are made of the small-signal linear transmission characteristics of a variety of lightwave components. A precise electrical (signal generator) or optical (laser) source is used to stimulate the component under test and a very accurate optical or electrical receiver measures the transmitted signal. Since characterization over a range of modulation frequencies is required, the frequency of modulation is normally swept over the bandwidth of interest.

Measurements are typically comprised of the appropriate ratio of microwave modulation current (or power) and lightwave modulation power.

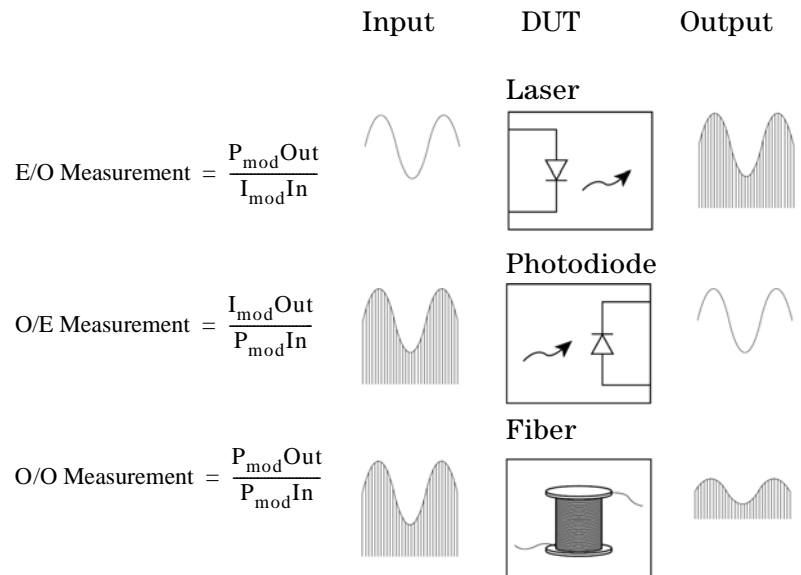
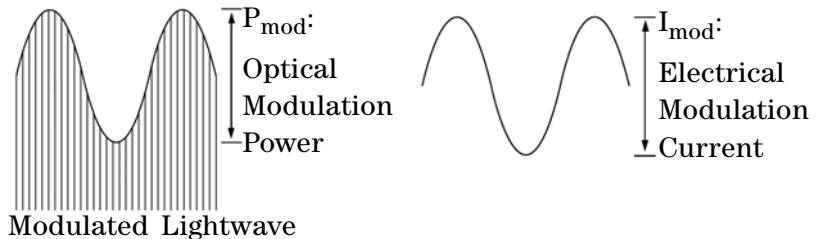

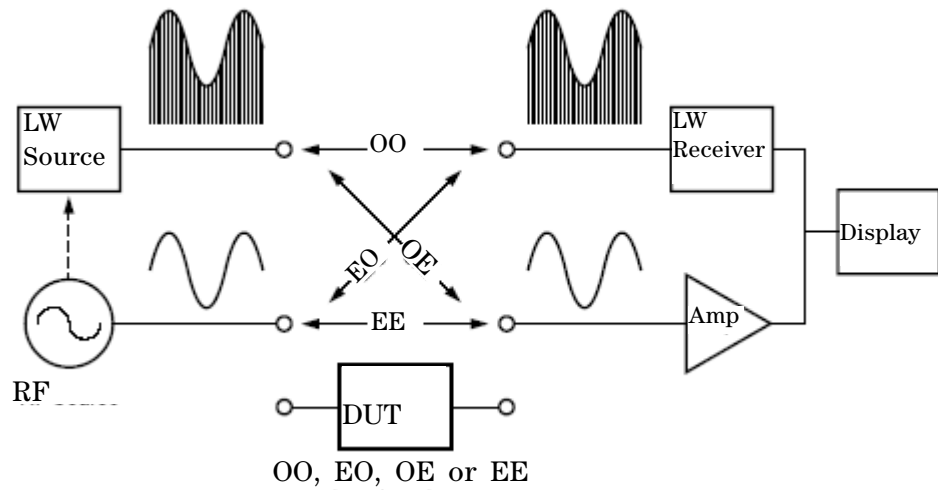
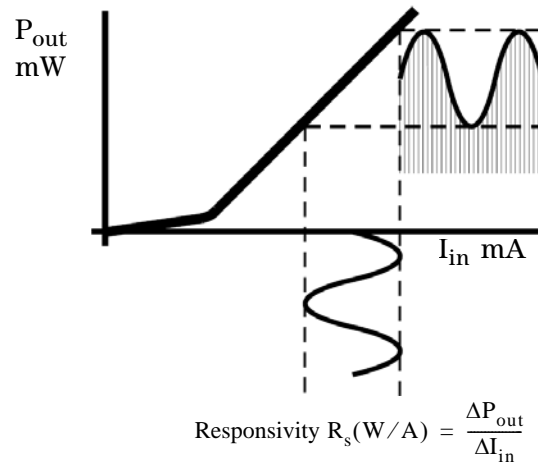

Figure 1 LCA Block Diagram

Figure 1 demonstrates the basic concepts of lightwave component analysis. An analysis of how various signals are used in the measurement process is found in “Signal Relationships in Opto-electric Devices” on page 46.

EO measurements (lasers, modulators)

The measurement of an EO transducer is a combination of input modulating current and output optical modulation power. Slope responsivity is used to describe how a change in input current produces a change in optical power. Graphically this is shown in the figure below.



$$\text{Responsivity } R_s (\text{W/A}) = \frac{\Delta P_{\text{out}}}{\Delta I_{\text{in}}}$$

$$R_s (\text{dB}) = 20 \log_{10} \frac{R_s (\text{W/A})}{\text{W/A}}$$

An LCA measures input modulating current and output modulation power and displays the ratio of the two in Watts/Amp, either linearly or in decibels.

OE measurements (photodiodes)

The measurement process for OE devices is similar to EO devices. The measurement consists of the ratio of output electrical modulation current to input optical modulation power. Slope responsivity for OE devices describes how a change in optical power produces a change in electrical current. Graphically this is shown in the figure below.

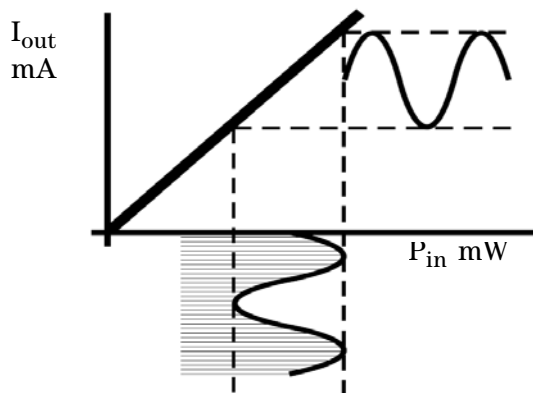

$$\text{Responsivity } R_r(\text{A/W}) = \frac{\Delta I_{\text{out}}}{\Delta P_{\text{in}}}$$

$$R_r(\text{dB}) = 20 \log_{10} \frac{R_r(\text{A/W})}{\text{A/W}}$$

The LCA measures the input optical modulation power and output modulation current and displays the ratio of the two in Amps/Watt.

OO measurements

Characteristics of purely optical devices can also be measured. In this case, both the stimulus and response are modulated light. The ratio measurement is simply one of gain or loss versus modulation frequency.

As the multimode lightwave component analyzer is able to measure amplitude with very high frequency resolution, it can be used to characterize narrowband optical components with a very high frequency resolution within the modulation bandwidth.

Signal Relationships in Opto-electric Devices

The LCA measurement technique is built upon concepts used in characterizing RF and microwave devices. “S-parameter” or scattering matrix techniques have proven to be convenient ways to characterize device performance.

The following section will discuss how similar techniques are used in characterizing devices in the lightwave domain. This is intended to show the basis on which EO and OE responsivity measurements are defined.

The figure below is a general representation of a lightwave system, showing input and output signals in terms of terminal voltages, input and output currents, and optical modulation power.

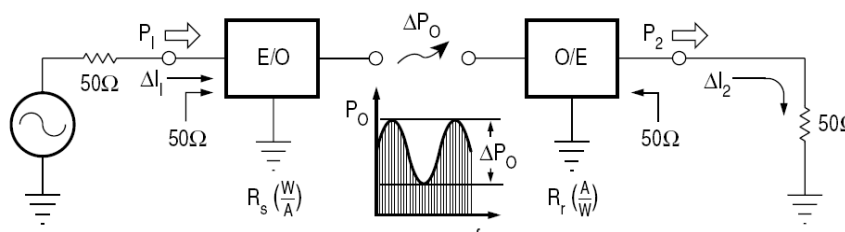

S-parameters are used to describe the transmitted and reflected signal flow within a device or network. For the model, the following S-parameters are defined:

$$S_{11} = \frac{b_1}{a_1} (a_2 = 0)$$

$$S_{22} = \frac{b_2}{a_2} (a_1 = 0)$$

where:

$$a_1 = \frac{\Delta V_1}{\sqrt{Z_0}} \quad \text{incident on E/O device}$$

$$= \Delta I_1 \cdot \sqrt{Z_0}$$

$$b_1 = \frac{\Delta V_{1\text{refl}}}{\sqrt{Z_0}} \quad \text{reflected from E/O device}$$

$$a_2 = \frac{\Delta V_2}{\sqrt{Z_0}} \quad \text{incident on E/O device}$$

$$\begin{aligned}
 b_2 &= \frac{\Delta V_{2\text{refl}}}{\sqrt{Z_0}} && \text{reflected from E/O device} \\
 &= \Delta I_2 \cdot \sqrt{Z_0}
 \end{aligned}$$

It is interesting to note that delta voltages and currents are used as opposed to RMS values. This is done because we deal with modulation signals in describing lightwave transducers, where a change in optical power is proportional to a change in electrical current or voltage.

The overall system forward gain is defined as:

$$\begin{aligned}
 S_{21} &= \frac{b_2}{a_1} (a_2 = 0) \\
 S_{12} &= 0 && \text{(no reverse transmission is assumed)}
 \end{aligned}$$

Though the overall system gain is defined as an S-parameter, the individual transfer functions of the EO and OE devices are typically defined in terms of responsivities, because signals in both the optical and electrical domain are used and optical signals do not lend themselves conveniently to S-parameter definitions. Initially, the input impedance of the EO converter and the output impedance of the OE converter will be assumed to be Z_0 (thus S_{11} and S_{22} are zero).

$$R_s = \frac{\Delta P_0}{\Delta I_i} = \text{E/O source res}$$

and

$$R_r = \frac{\Delta I_2}{\Delta P_0} = \text{O/E receiver res}$$

Using the above relationships, we can rewrite S_{21} in terms of the transducer responsivities R_s and R_r :

$$\begin{aligned}
 S_{21} &= \frac{b_2}{a_1} \\
 &= \frac{\Delta I_2}{\Delta I_1} \\
 &= \frac{(R_r \cdot \Delta P)}{(\Delta P / R_s)} \\
 &= R_s \cdot R_r
 \end{aligned}$$

It is convenient to express the transducer functions logarithmically in decibels. The system power gain from a Z_0 source to a Z_0 load can be defined using the above relationships:

$$|a_1|^2 = \text{Power incident on the E/O converter}$$

Power delivered to a

$$\begin{aligned}
 |S_{21}|^2 &= \frac{|b_2|^2}{|a_1|^2} \\
 &= |R_s \cdot R_r|^2 \\
 &= \text{System power gain} \\
 20\log_{10}|S_{21}| &= \text{System gain in dB} \\
 &= 20\log_{10}|R_s \cdot R_r|
 \end{aligned}$$

The responsivities R_s and R_r need to be related to some value in order to have meaning as individual quantities expressed logarithmically, just as 0 dB represents an S_{21} of unity or gain of 1.

Consequently source responsivity will be expressed in Watts per Amp, which in decibels will be related to a conversion efficiency of 1 W/A. Similarly, receiver conversion efficiency will be relative to 1 A/W.

$$20\log_{10}|R_s \cdot R_r| = 20\log_{10} \frac{R_s(W/A)}{W/A} \cdot \frac{R_r(A/W)}{A/W}$$

The individual responsivities can now be expressed individually in decibels:

$$R_s(\text{dB}) = 20\log_{10} \frac{R_s(W/A)}{W/A}$$

$$R_r(\text{dB}) = 20\log_{10} \frac{R_r(A/W)}{A/W}$$

This now allows us to express the original equations for responsivity in logarithmic terms:

$$R_s(\text{dB}) = 20\log_{10} \frac{\Delta P}{\Delta I_1}$$

$$R_r(\text{dB}) = 20\log_{10} \frac{\Delta I_2}{\Delta P}$$

Responsivity measurements are now based on the LCA's ability to accurately measure optical modulation power (ΔP_0) and modulation current ($\Delta I_{1,2}$).

The measurement of modulation current is derived from the system characteristic impedance and a measurement of electrical power.

The measurement of optical modulation power is based on a "standard" lightwave receiver whose characteristics are predetermined and known by the LCA.

Single-Ended Measurements

Single port measurements are made on devices when the signal on the electrical port is referenced to ground. This port is described by S-parameters.

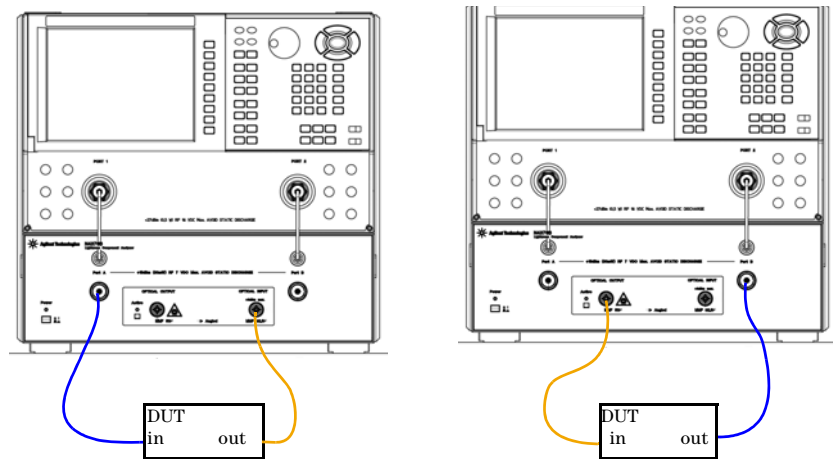

Figure 1 Single ended EO (left) and OE measurement setups
(Electrical connections shown in blue, optical connections in yellow)

Differential Measurements

Differential measurements are made on devices when the signal on the electrical port is the difference between two electrical signals, each of which is referenced to ground. A differential measurement needs two input or two output channels on the network analyzer. The optical port of the device is a third port. For valid differential measurements, make sure the electrical calibration of the network analyzer includes at least three ports.

For more details on differential measurements, please consult the network analyzers user's guide.

For differential device measurements the LCA assumes fixed port configuration. The physical ports 1 and 4 on the network analyzer connect to the LCA test set. The physical ports 2 and 3 on the network analyzer connect to the differential electrical ports of the DUT. shows the physical setup for EO measurement and OE measurement, respectively.

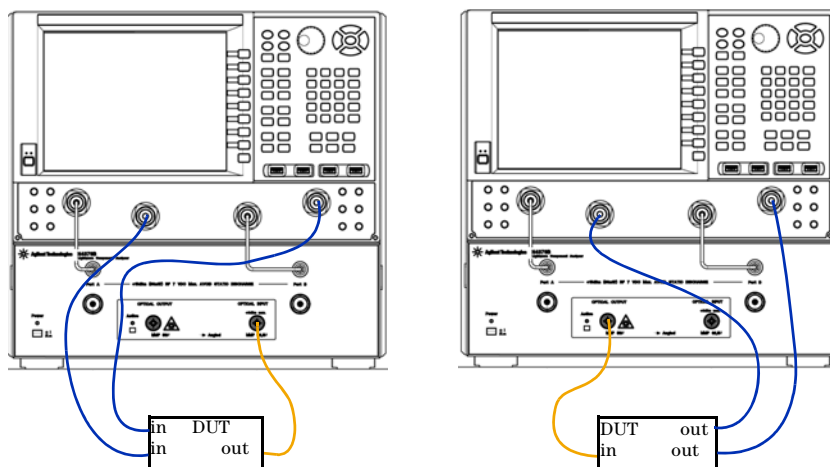

(Electrical connections shown in blue, optical connections in yellow)

Figure 2 Differential EO (left) and OE measurement setups

For the differential measurement the logical port configuration of the network analyzer need to be set as follows:

- Logical port 1 is assigned to the single ended, unbalanced port and
- Logical port 2 is assigned to the balanced, differential port.

Differential OE measurements

For OE measurements the single-ended (SE), logical port 1 is assigned to physical port 1 and the balanced (BAL), logical port 2 is assigned to the physical ports 2 and 3 (see Figure 3).

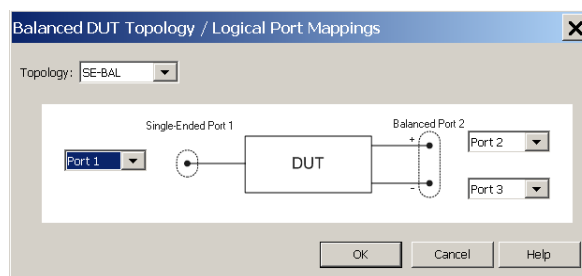

Figure 3 Logical Port Mapping for OE measurement

For OE measurements, the LCA sets up traces for S22, S21, S33, S31 by default.

Differential EO measurements

For EO measurement the single-ended (SE), logical port 1 is assigned to physical port 4 and the balanced (BAL), logical port 2 is assigned to physical ports 2 and 3 (see Figure 4).

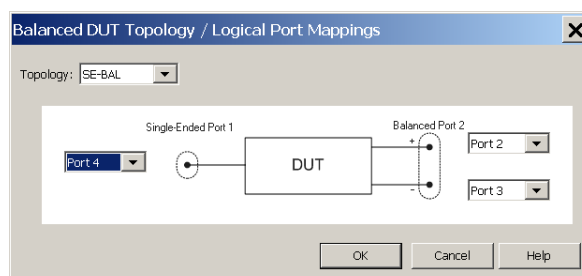

Figure 4 Logical Port Mapping for EO measurement

For EO measurements the LCA sets up traces for S22, S42, S33, S43 by default.

Differential results

When measuring differential devices, the network analyzer displays traces of interest for balanced devices. These include, differential responsivity S, common mode rejection or port imbalance.

Since opto-electronic components are unidirectional, non-reciprocal devices, only the measurement types circled in Figure 5 are relevant.

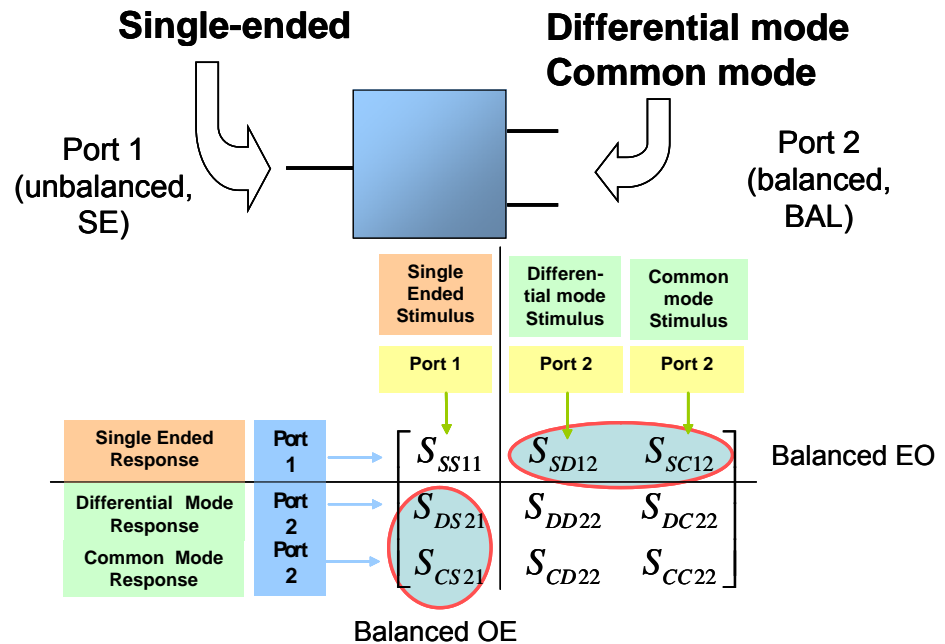

Figure 5 Balanced Measurement types for opto-electronic components

Calibration Concept

The key to making accurate EO, OE, or OO measurements is calibrated instrumentation.

There are a number of calibration stages involved.

With the N4376D "Lightwave Component Analyzer" all calibrations and measurements relate to a valid electrical calibration. For single-ended measurements, this is a full 2-port calibration. For balanced measurements, this is a full 3-port calibration. Any electrical and optical factory calibrations are made with reference to the front panel of the "Optical Test Set" of the N4376D "Lightwave Component Analyzer".

The internal optical transmitter of the N4376D "Lightwave Component Analyzer" has a calibrated optical transmission over frequency to the "Optical Output" on the front panel with respect to an electrical calibration plane on "Port A" on the front panel.

Therefore, when making O/E measurements one electrical calibration plane must be coincide with "Port A" on the front panel.

In other words: the calibration standards used for electrical calibration must connect directly to "Port A".

The internal optical receiver of the N4376D "Lightwave Component Analyzer" has a calibrated optical transmission over frequency from the "Optical Input 1" on the front panel with respect to an electrical calibration plane on "Port B" on the front panel.

Therefore when making E/O measurements one electrical calibration plane must be coincide with "Port B" on the front panel.

In other words: the calibration standards used for electrical calibration must connect directly to the "Port B".

Similarly, when making O/O measurements or when making user calibrations the electrical calibration planes must coincide with "Port A" and "Port B" on the front panel.

When necessary, you can modify the optical calibration planes using "optical path deembedding" (see "Optical Path Deembedding" on page 65) or modify the electrical calibration planes using "RF path deembedding" (see "RF Path Deembedding" on page 66).

Measuring 75 Ohm devices

Since the system impedance of the LCA system is 50 Ohm, some additional steps are required to measure devices with 75 Ohm impedance.

The system expects a valid 50 Ohm electronic calibration to the end of the RF cables is available and active.

On the LCA user interface you need to check the 75 Ohm checkbox. This checkbox is only enabled when the "RF Path Deembedding" is also enabled. The LCA assumes that your device is connected with minimum loss pads for impedance conversion.

In the "RF Path Deembedding" box you need to specify the deembedding data for the minimum loss pads.

Internally the LCA sets the reference impedance of the network analyzer to 75 Ohm, scales the receiver or transmitter calibration data to a 75 Ohm environment and adds the minimum loss pad data to the deembedding data for the network analyzer. This extends the calibration reference plane to the 75 Ohm DUT interface.

The files delivered with the LCA are typical data for the Agilent 11852B minimum loss pads. By default, they are located on the network analyzer at

```
C:\Program Files\Agilent\LCA\CalData\MLP  
Adapter\11852B.s2p
```

If you want to use data for your individual pads, measure them using the adapter characterization utilities on your PNA network analyzer. On the PNA Series Network analyser the characterization can be performed using mechanical or electronic calibration kits.

The adapter characterization procedure is described in detail in an application note.

Triggering Concepts

It is possible to trigger the DUT measurements either directly on the network analyzer or using the LCA software, by pressing the LCA "Single" or "Continuous" keys.

However there are some differences:

- when the modulator bias optimization mode is set to "Every Sweep" or "Continuous", using the LCA software starts a modulator bias optimization before starting a DUT measurement. This is not done when triggering the measurements directly on the network analyzer.
- when doing EO or OO measurements, using the LCA software, it measures the DC level of the optical power on the receiver, and adjusts the deembedding data if necessary. This means more accurate results than a measurement started directly on the network analyzer. During "LCA Measurement Setup" it is assumed that the DUT has no optical loss and the receiver deembedding is setup for a DC power level equal to the selected optical output power of the LCA. When the internal light source is not used (EO measurement in "Default" mode), the receiver deembedding is setup for a DC power level of 0.0 dBm.

During measurements started using the LCA software, the network analyzer does not respond to any keystrokes on the keypad. The only way to stop a measurement during a sweep is to press the "Abort" button in the "Sweeping..." window (which is shown on the display).

In some cases it makes sense to start a measurement directly on the network analyzer. For example, when the time for a single sweep is shorter than a certain limit, the "Sweeping..." window is no longer shown. This happens with a low number of measurement points and a high bandwidth setting on the network analyzer. Such a measurement can only be stopped in the time between two sweeps.

When doing an OE measurement with modulator bias optimization mode set to "Single", this time window is very short, since the LCA does nothing between the sweeps. In such cases, the running measurements can always be stopped by pressing the "Abort Measurement" button on the LCA Server window.

where *SN...* is the serial number of the optical test set.



5

User Interface Reference

The LCA Function Keys	58
Default and Advanced Measurement Parameters	60
Saving and Loading Setups	60
The Measurement Parameters	62
Tools	67

The LCA Function Keys

1. If the LCA server is running, but the function keys are not displayed, press the [Macro/Local] Utility key until they appear.



-  : Brings the LCA user interface to the foreground, to setup an LCA measurement.
-  : Perform a single sweep measurement with the current measurement setup.



Pressing this function key when a single or continuous measurement is running, stops this measurement and starts a new, single sweep measurement.

-  : Perform continuous measurement sweeps with the current measurement setup.

Pressing this function key during a single or continuous measurement, stops the measurement.

-  : Start the optical power monitor. This uses the current measurement setup to determine the wavelength and the optical input for which the average optical power is measured.
-  : If it is not already running, this starts the LCA server. If it is already running, it brings the server to the foreground.

For information on further function keys, please refer to the documentation supplied with the network analyzer.

NOTE

After completing the “LCA Measurement Setup” step, the network analyzer is ready for DUT measurements.

Because the receiver responsivity depends on the optical power, you should start the DUT measurements with the LCA “Single” or “Continuous” macros.

These macros perform an optical power measurement prior to each measurement sweep. This achieves the highest accuracy in EO and OO measurements.

If you do not need this accuracy, you can also start the DUT measurements with the network analyzer's trigger functions.

In some cases it can become difficult to abort continuous measurements by pressing the "Continuous" or "Single" button, since the network analyzer does not react to the keypad during measurements. If the "Sweeping..." window (with the "Abort" button) is not shown, abort the measurement with the "Abort Measurement" button in the LCA Server window.

For more information on triggering measurements, see “Triggering Concepts” on page 56.

Default and Advanced Measurement Parameters

Use the **default** parameters for EO, OE and OO measurements of devices with a simple stimulus and response path. This includes devices like sources, receivers or amplifiers.

Use the **advanced** parameters for more comprehensive control of your measurements. For example, to use the optical output as the DC light source to an optical modulator as part of an EO measurement.

Saving and Loading Setups

Saving setups

A setup contains the current state of the LCA user interface and optionally also the current state of the network analyzer. Setups are stored as XML-files or as compressed XML-files.

The settings on the “Tools” tab are not saved in the setup, since the settings shown on this tab always reflect the current state of the LCA hardware. After loading the setup the LCA system is configured to press “Start” from the LCA user interface.

There are two ways of saving setups.

First saving method

Click  to save the current setup.

- If user calibration mode is set to “Measure” (only possible for OE and OO measurements), you are asked to specify the electrical calibration set to be saved with the setup. This is the electrical calibration set to be used during user calibration measurements.

Only a link to the electrical calibration set is saved, not the calibration data itself.

For more details, see “Measuring Opto-Electrical (OE) Devices” on page 81 or “Measuring Optical-Optical (OO) Devices” on page 95.

- If User Calibration is set to “Load” (only possible for OE and OO measurements), you will be asked to specify which user calibration file should be loaded.

The filename of the calibration data is saved with the setup, not the calibration data itself.

For more details, see “Measuring Opto-Electrical (OE) Devices” on page 81 or “Measuring Optical-Optical (OO) Devices” on page 95.

Second saving method

After initializing with the User Calibration mode set to “Measure”, you are asked if you want to save the user calibration data and/or the LCA Setup.

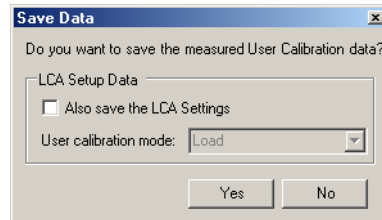

Check “Also save the LCA Setup” if you want to save the LCA setup. Then choose between “Load” and “Measure” to specify the user calibration mode to save with the setup.

- If you selected “Load”, the “No” button is disabled to force you to store the measured user calibration data.

After you press “Yes”, you are asked to specify the filename for the user calibration data and the filename of the LCA setup.

Only the filename of the user calibration data is saved with the setup.

- If you selected “Measure”, it is also possible to press the “No” button. In this case only the LCA setup is saved.

If you press “Yes”, you are asked for the filename of the LCA setup. The name of the electrical calibration set just used for this user calibration measurement will be saved in the LCA setup.

Before the LCA saves the setup, it asks you whether you want to save the network analyzer state with your LCA setup.

Loading setups

Click  to retrieve an existing setup.

- After loading a setup with user calibration mode set to “Measure”, the electrical calibration set specified in this setup is preselected in the optical connection dialog shown during OE or OO initialization. This is different to the behavior when doing OE or OO initialization without loading a setup.

For more details, see “Measuring Opto-Electrical (OE) Devices” on page 81 or “Measuring Optical-Optical (OO) Devices” on page 95.

- After loading a setup with user calibration mode set to “Load”, the specified calibration file is preselected in the load dialog asking you for the calibration data file during OE or OO initialization.

For more details, see “Measuring Opto-Electrical (OE) Devices” on page 81 or “Measuring Optical-Optical (OO) Devices” on page 95.

The Measurement Parameters

Measure Mode



A 2-port network analyzer can only support single-ended measurements. Selecting the Measure Mode is only possible if you have a 4-port network analyzer.

Differential

If you select this mode, means the LCA uses a differential electrical input or output for this measurement.

Whether the differential signal is the input to the DUT or the output from the DUT, this uses ports 2 and 3 of a four port network analyzer.

Single-Ended

If you select this mode, the LCA uses a single-ended electrical input or output for this measurement.

The electrical input to the DUT is Port A of the optical test set.

The electrical output from the DUT is port B of the optical test set.

LCA System Settings

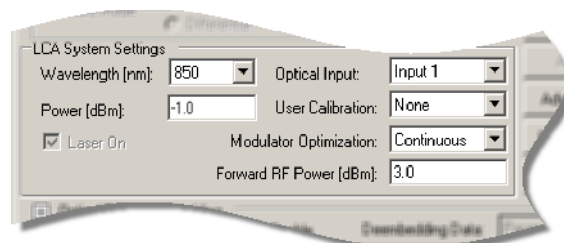

Wavelength (nm)

- Select the wavelength of the laser source and the optical power meter use for measurements.

Power [dBm]

Set the optical output power of the internal laser source.

Laser On

This control, which overrides the default behavior of the Lightwave Component Analyzer, is only enabled in Advanced mode.

Select to turn the laser source on for the following LCA measurement.

Deselect to turn the laser source off for the following LCA measurement.

Optical Input

- For input signals up to +3 dBm (calibrated up to 0 dBm), use **Input 1**.

User Calibration

Select the calibration data you want to use.

- **None** uses the factory calibration data only (no additional user calibration data is used).
- **Measure** runs an extra calibration measurement step during the measurement setup.

Before running the first measurement, you need to ensure the instrument has a valid electrical calibration, as described in “Calibrating the Network Analyzer before Measurements” on page 72.

At the end of this calibration measurement, you can save the calibration data.

This calibration is only used for the measurement setup for which it is specified.

- **Load** prompts you to load data from a file saved as part of a previous user calibration measurement.

Modulator Optimization

Select to how the modulator bias is to be optimized.

- Select “Once” to automatically optimize the modulator bias at the first measurement after the measurement parameters have been set.

This is sufficient for most measurements unless the tester is subject to large changes in environmental conditions.

- Select “EverySweep” to optimize at the start of every measurement sweep.

This increases accuracy, but also increases measurement times.

- Select “Continuous” to optimize while the measurement is running.

This is the default modulator bias optimization mode, and is used to calibrate and verify the instrument.

With “Continuous” modulator bias optimization, a 10 kHz pilot tone is applied to the signal. This improves the short and long term signal stability of the modulator working point.

The pilot tone will affect measurements with IFBW settings of the network analyzer >1.5 kHz.

For IFBW settings of the network analyzer >3 kHz we recommended you do not use “Continuous” modulator bias optimization, Use "Every Sweep" or "Once" instead.

Not using “Continuous” modulator bias optimization affects the accuracy of the internal transmitter calibration. We recommend you include a “User Calibration” in your setup (“User Calibration” on page 63) if you not using “Continuous” modulator bias optimization.

Forward RF Power [dBm]

Sets the RF power level for the source port(s).

Optical Path Deembedding

Enable

Select if you want the LCA to compensate for the optical connections to the DUT.

Deembedding Data

Select how you want to specify the characteristics of the optical path.

- **Parameter** lets you characterize the source or receiver optical path by its length and refractive index, and attenuation.

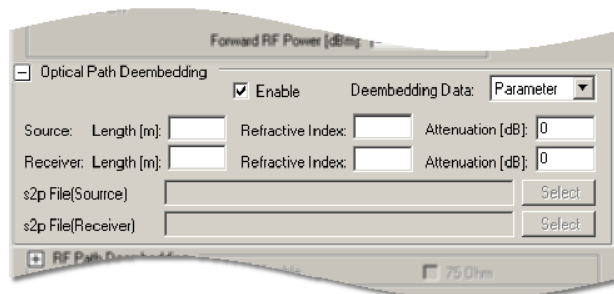

- **Length (m)** and **Refractive Index** can only be used together. That is, you cannot give a value just for the refractive index or just the length.

The value for the Refractive Index of a graded index multi-mode fiber is 1.49 for 62.5 μm at 850 nm, 1.475 for 50 μm at 850 nm and 1.465 for 50 μm at 1300 nm.

- **Attenuation (dB)** can be used alone, or with the values for length and refractive index.

- **File** lets you use the results of a measurement of the optical path to characterize the source or receiver optical path.

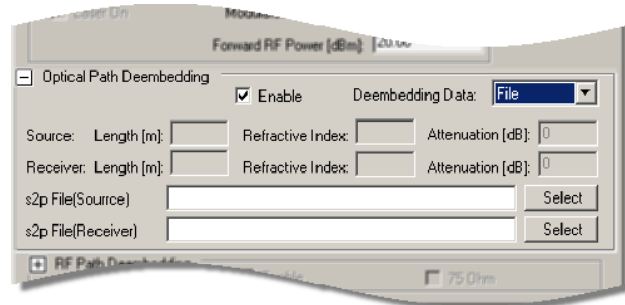

These results need to be in the form of a 2-port S-parameter data files (also known as Touchstone .s2p data files).

Only the s21 values of the file are used for correction of the transmission properties. All other parameters are ignored.

To assign a file,

- Click **Select** at the right of the field to which you want to assign a file.
- Locate and select the file in the explorer window.

RF Path Deembedding

Enable

Select if you want the LCA to compensate for the RF connections to the DUT.

Use the results of a measurement of the RF path to characterize the source or receiver RF path.

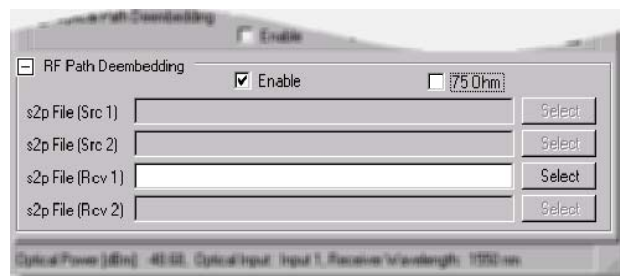

- For Single-Ended measurements, Src 1 corresponds to the path to Port A, and Rcv 1 corresponds to the path to Port B.

- For Differential measurements, Src 1 corresponds to the path to Port 2 (on the PNA), Src 2 corresponds to the path to Port 3 (on the PNA), Rcv 1 corresponds to the path to Port 2 (on the PNA), Rcv 2 corresponds to the path to Port 3 (on the PNA).

The results need to be in the form of a 2-port S-parameter data file (also known as Touchstone .s2p data files). All the S-Parameters in the supplied file are used.

According to the convention of the LCA (where any port can be an input or an output), these values are directional. This means port 1 of the connector is always connected to the network analyzer and port 2 is always connected to the DUT. We recommend you use the AdapterChar macro supplied with the network analyzer. This includes this directionality in its characterization. Please refer to the online help on the Network Analyzer for further details.

To assign a file,

1. Click .
2. Locate and select the file in the explorer window.

75 Ohm

Select if you measure components with 75 Ω impedance. Insert the s2p file name for the file that characterizes the minimum loss pad.

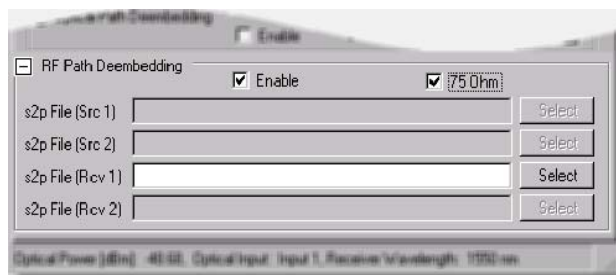

Tools

Some of the controls that can be selected on the Tools tab are also available on the measurement tabs.

The controls on the measurement tabs are activated when you start the next measurement setup.

The controls on the Tools tab are activated immediately.

The Tools tab always showing the current settings of the instrument. These may be different to what is selected on the other tabs.

Laser Source

Source Wavelength (nm)

Set the wavelength of the laser source.

Power [dBm]

Set the optical output power of the laser source.

Laser On

- Select to turn the laser source on.
- Deselect to turn the laser source off.

Optimize ModBias

Start an immediate bias optimization for the modulator.

Receiver

Optical Input

- For input signals up to +3 dBm (calibrated up to 0 dBm), use **Input 1**.

Receiver Wavelength (nm)

Set the wavelength of to be used by the optical power meter.

RF Power

The recommended settings of Forward and Reverse RF power depend on the type of measurement and your network analyzer.

For EE measurements and electrical calibrations we recommend -12 dBm as RF power (Forward and Reverse). For accurate electrical calibrations we recommend you use these values. For EE-measurements you can increase these to the maximum leveled output power.

For optical measurements (OE, EO and OO) we recommend +3 dBm as Forward RF power and 0 dBm as Reverse RF power. Changing the RF powers from the values given here may affect factory calibration of the optical test set. If you change these values, we recommend you use a "User calibration".

Forward RF Power [dBm]

Sets the RF power level for the source port(s).

For balanced measurements (on 4-port network analyzers), Ports 2 and 3 of the network analyzer are forward for EO measurements and reverse for OE measurements.

Increasing the forward RF power for OE measurements increases the optical modulation amplitude.

Reverse RF Power [dBm]

Sets the RF power level for the receiver port(s).

We recommend the factory calibrated default value for the best results.

To reset to the factory default, leave the text box empty or enter a value less than -200 dBm.

RF Switches

Source Switch

- Select "Intern" to switch the source RF signal from the network analyzer to the EO modulator in the optical test set.
- Select "Thru" to switch the source RF signal from the network analyzer directly to Port A of the optical test set.

Receiver Switch

- Select "Intern" to switch the signal from the optical receiver of the optical test set, to the RF receiver of the network analyzer.
- Select "Thru" to switch the Port B of the optical test set directly to the RF receiver of the network analyzer.

NOTE

Selecting “UnKnown” leaves the switch setting as it is.

“UnKnown” is used to show the status of the switch when the LCA application starts first.

NOTE

Setting both source and receiver switches to “Thru” is not the same as selecting an EE Measurement.

Selecting an EE Measurement also resets further settings, such as the RF powers and fixture deembedding.

Reset UI

The "Reset UI" button resets all LCA settings to default settings.

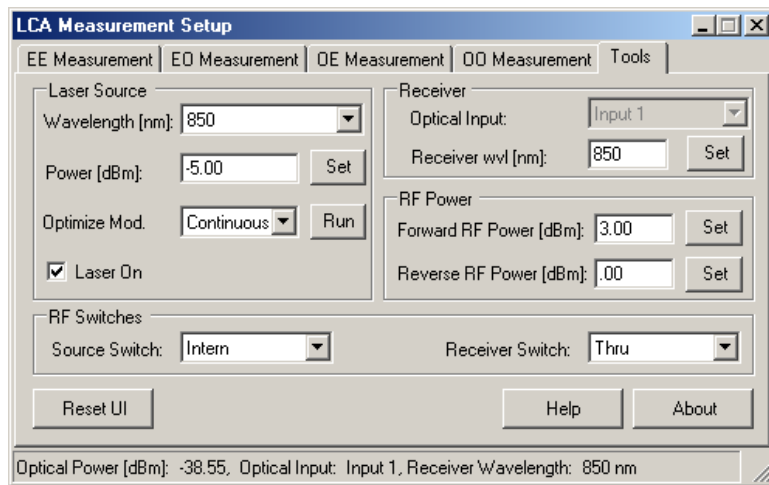

6

Making Measurements

Starting the Lightwave Component Analyzer	72
Calibrating the Network Analyzer before Measurements	72
Measuring Opto-Electrical (OE) Devices	81
Measuring Electro-Optical (EO) Devices	90
Returning to Electrical Measurements	94
Measuring Optical-Optical (OO) Devices	95
Measuring Optical Power	101

Starting the Lightwave Component Analyzer

1. Turn on the network analyzer and the optical test set.
2. Allow the Lightwave Component Analyzer to warm up. Both the optical test set and the network analyzer need to stabilize their internal temperature.

Please refer to “Explanation of Terms” on page 137 for information on settling.

3. If it does not start automatically, click on the icon on the desktop to start the network analyzer application.

NOTE

When starting the “LCA Measurement Setup” with no server running, the LCA server is started automatically.

4. If it is not already running, start the LCA server by pressing , or by clicking the LCA server icon on the desktop.

See “The LCA Function Keys” on page 58 for information on displaying the LCA function keys.

Calibrating the Network Analyzer before Measurements

About measurements

Please refer to “Optimize a measurement” and “Calibrate a measurement” in the documentation for the network analyzer.

- Always perform an electrical calibration of the network analyzer or load an existing calibration set before making measurements.
- Always make sure that, on the network analyzer, in the sweep setup menu, that “Stepped sweep - sweep moves in discrete steps” is selected.
- Always make sure that the LCA has been reset to EE measurement mode before starting an electrical calibration.
 - After completing the calibration, do not alter the IF bandwidth, start frequency, stop frequency, measurement point number or other settings. You may get measurement errors if you change the parameters.

Keep the following points in mind during network analyzer electrical calibration.

- To get the best S/N ratio for your measurements, use the recommended settings of Forward and Reverse RF power for the type of measurement and your network analyzer, as given in “RF Power” on page 68.
- Decreasing the IF bandwidth improves the S/N ratio of the measurement. However, doing so increases the calibration and measurement times, so a suitable IF bandwidth should be selected.
- Apply appropriate averaging or smoothing for your application.

Electrical calibration for “User Calibration” and OO measurements

Calibrate before you start using the Lightwave Component Analyzer, or return to EE measurement mode, as described in “Returning to Electrical Measurements” on page 94 in order to calibrate.

To calibrate for measurements using “User Calibration” or for OO measurements.

NOTE

We recommend you use the torque spanner (Agilent part number 8710-1764, 0.90 Nm, 8 lb.-in) supplied with the optical test set to tighten all RF connections during the calibration.

1. Set your measurement parameters.
2. From the “Calibration” menu, select “Calibration Wizard”.
3. Select “Use Electronic Calibration”, and click [Next>].

4. Select “2 Port ECal”.

On two-port network analyzers select port 2 as "selected 2nd port".

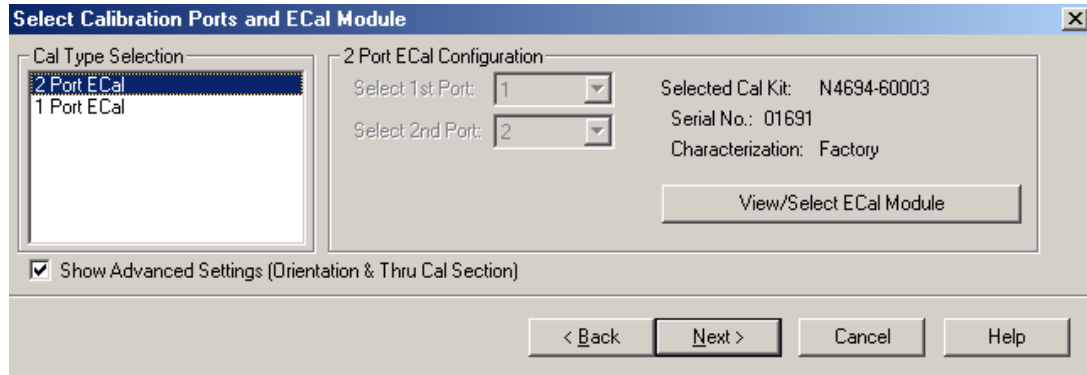

On 4-port network analyzers select port 4 as "selected 2nd port".

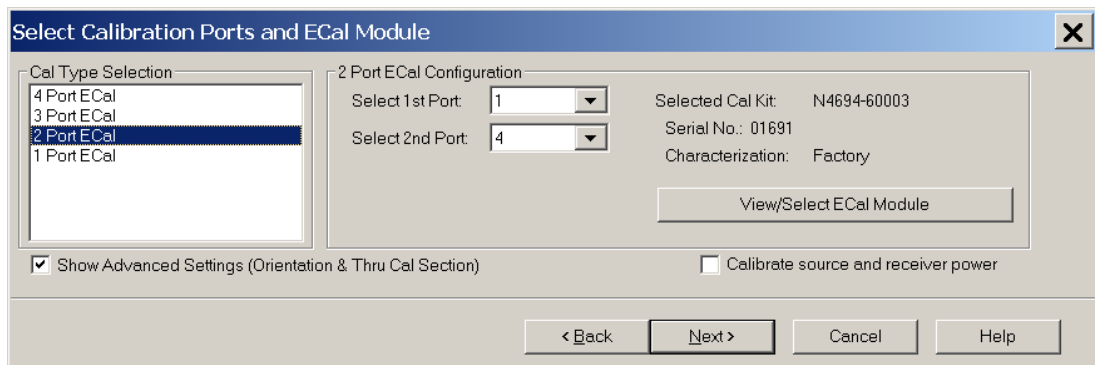

5. Select 2nd Port as the 2 Port ECal Configuration according to the screen shot.

6. If necessary, select the appropriate ECal Module.

7. Make sure “Show Advanced Settings” is selected.

8. Click [Next>].

9. Make sure “Do orientation” is selected.

10. Select “Unknown Thru”, and click [Next >].

11. In step 1 of 3, connect ECal module to Port A of the optical test set.
12. Click [Measure].



13. In step 2 of 3, connect the ECal module to Port B of the optical test set.
14. Click [Measure].



15. Connect the thru calibration adapter (Agilent part number N4373-61627, RF 3.5 f-3.5 f, supplied with the optical test set) between Port A and B of the optical test set.
16. Click [Measure].



17. Enter the adaptor delay as noted on the thru calibration adapter, and click [OK].
18. Save the calibration set under a name you will recognize. You will need to specify this electrical calibration set when making a user calibration for OO or OE measurements.

Electrical calibration for single-ended EO and OE measurements

NOTE

If you are connecting the RF port of your DUT directly to the front panel connector of the optical test set, perform the calibration described in “Electrical calibration for “User Calibration” and OO measurements” on page 73, instead of the calibration described here.

To ensure the specified performance of the LCA, you should perform a full two-port electrical calibration. We recommend you use the appropriate electrical RF calibration kit. See the Agilent website for available calibration kits.

Calibrate before you start using the Lightwave Component Analyzer, or return to EE measurement mode, as described in “Returning to Electrical Measurements” on page 94 to calibrate.

NOTE

When using the ECal Module, we recommend you connect the RF cable to the ECal module before connecting the ECal module to the RF ports A or B of the LCA test set .

NOTE

We recommend you use the torque spanner (Agilent part number 8710-1764, 0.90 Nm, 8 lb.-in) supplied with the optical test set to tighten all RF connections during the calibration.

1. Set your measurement parameters.
2. From the “Calibration” menu, select “Calibration Wizard”.
3. Select “Use Electronic Calibration”, and click [Next>].
4. Make sure “Show Advanced Settings” is selected.
5. Select “2 Port Ecal”, and click [Next>].
On two-port network analyzers select port 2 as "selected 2nd port".

On 4-port network analyzers select port 4 as "selected 2nd port".
6. Select the appropriate Cal Kit for each port, or “ECal Thru as Unknown”.
7. Make sure “Do Orientation” is selected, and click [Next >].
8. Connect the ECal module and RF cable you will be using to connect to your DUT between the Port A and Port B.

For OE measurements, connect the ECal module directly to Port A, and the RF cable to Port B.



For EO measurements, connect the ECal module directly to Port B, and the RF cable to Port A.



9. Click [Measure].
10. When the calibration finishes, save the calibration file for later reuse.

Electrical Calibration for Differential OE Measurements

To ensure the specified performance of the LCA, you should perform a full three-port electrical calibration. We recommend you use the appropriate electrical RF calibration kit. See the Agilent website for available calibration kits.

Calibrate before you start using the Lightwave Component Analyzer, or return to EE measurement mode, as described in “Returning to Electrical Measurements” on page 94 to calibrate.

NOTE

We recommend you use the torque spanner (Agilent part number 8710-1764, 0.90 Nm, 8 lb.-in) supplied with the optical test set to tighten all RF connections during the calibration.

Making Measurements

1. Set your measurement parameters.
2. From the “Calibration” menu, select “Calibration Wizard”.
3. Select “Use Electronic Calibration”, and click [Next>].
4. Make sure “Show Advanced Settings” is selected.
5. Select “3 Port ECal”, Select 3 Port ECal Configuration according to the screen shot.

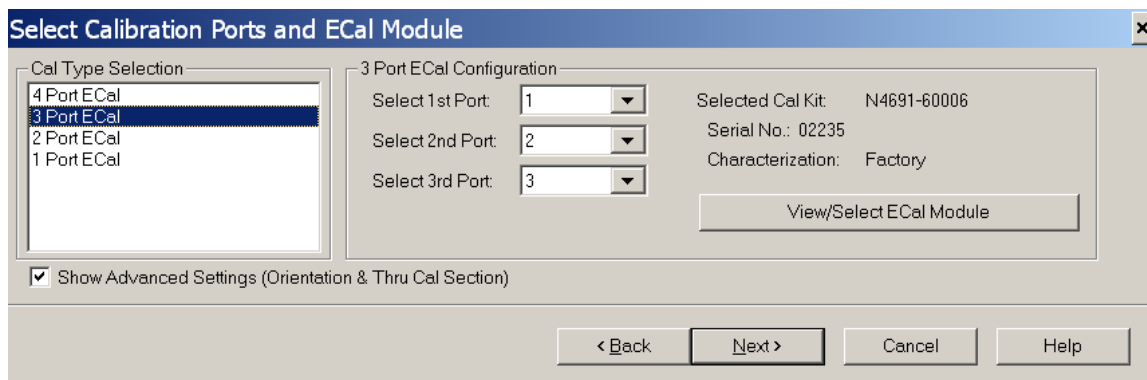

6. Click the [Next>] button.
7. Select “Thru #1 and “Thru #2” according to the screen shot.

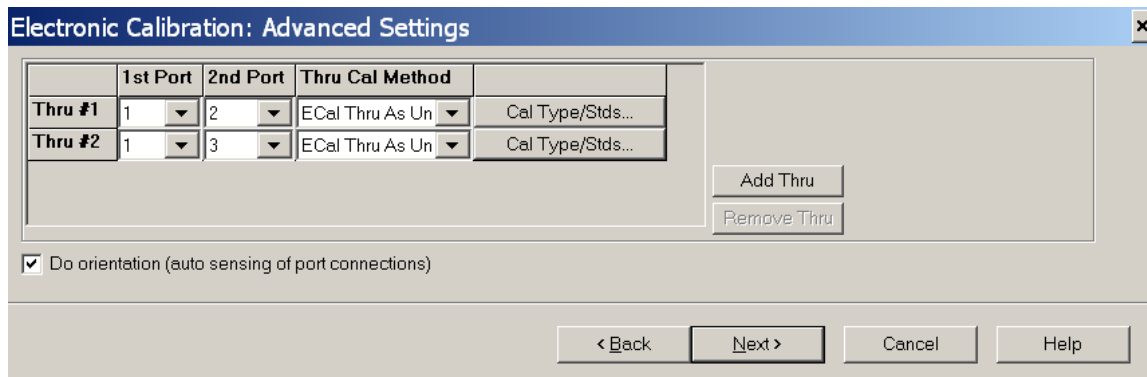

8. Select the appropriate Cal Kit for each port, or “ECal Thru as Unknown”.
9. Make sure “Do Orientation” is selected, and click [Next >].
10. When using the 2 port ECal module connect the ECal Module to Port A and the RF Cables to NWA ports 3 and 2, respectively.

11. Follow the instructions by the ECal Wizard. Click [Measure].



12. Repeat for other RF cable.

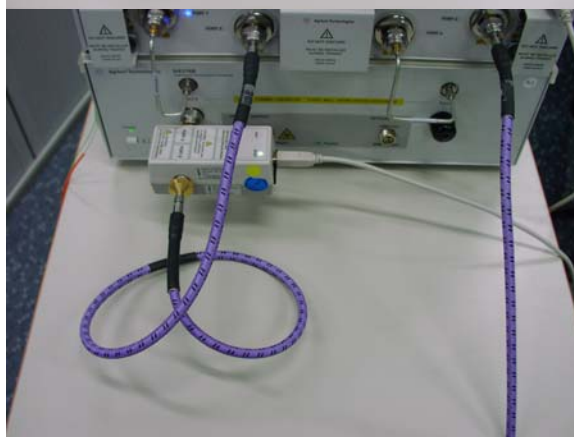

13. When the calibration finishes, save the calibration file for later reuse.

Electrical Calibration for Differential E0 Measurements

1. Set your measurement parameters.
2. From the “Calibration” menu, select “Calibration Wizard”.
3. Select “Use Electronic Calibration”, and click [Next>].
4. Make sure “Show Advanced Settings” is selected.
5. Select “3 Port Ecal”, Select 3 Port ECal Configuration according to the screen.

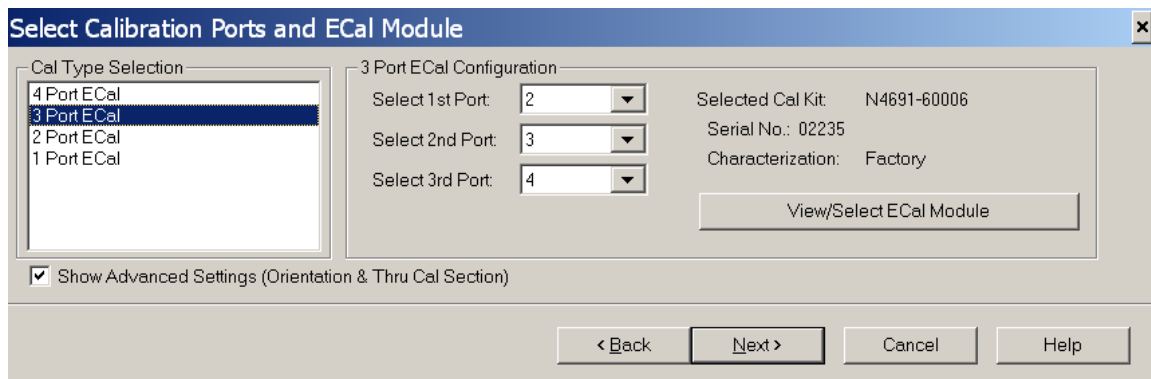

Making Measurements

- Click the [Next>] button.
- Select “Thru #1 and “Thru #2” according to the screen.

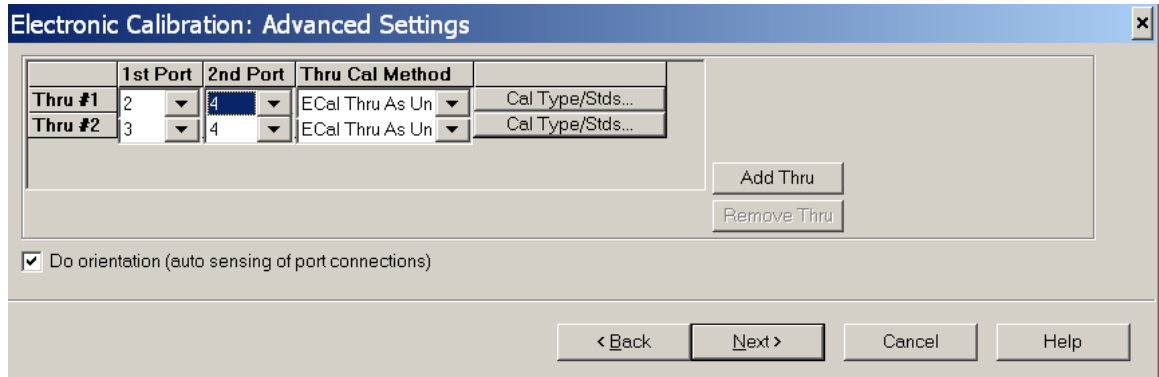

- Select the appropriate Cal Kit for each port, or “ECal Thru as Unknown”.
- Make sure “Do Orientation” is selected, and click [Next>].
- When using the 2 port ECal module connect the ECal Module to Port B and the RF Cables to NWA ports 3 and 2, respectively.
- Follow the instructions by the ECal Wizard. Click [Measure].



12. Repeat for other RF cable.
13. When the calibration finishes, save the calibration file for later reuse.

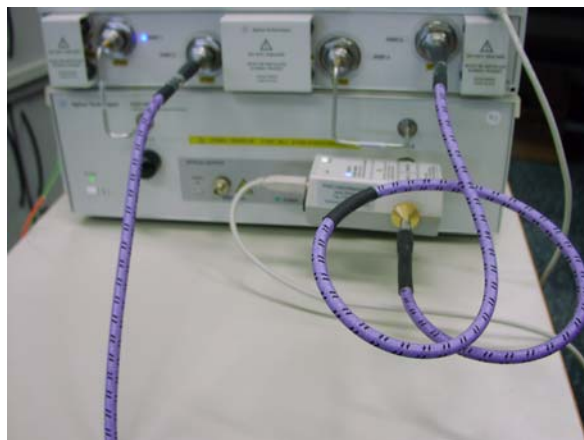

Measuring Opto-Electrical (OE) Devices

Always perform an electrical calibration of the network analyzer or load an existing calibration set before you make a measurement.

For standard measurements, see “Electrical calibration for single-ended EO and OE measurements” on page 75.

For differential measurements, see “Electrical Calibration for Differential OE Measurements” on page 77.

For differential OE measurements the single-ended (SE), logical port 1 is assigned to physical port 1 and the balanced (BAL), logical port 2 is assigned to the physical ports 2 and 3.

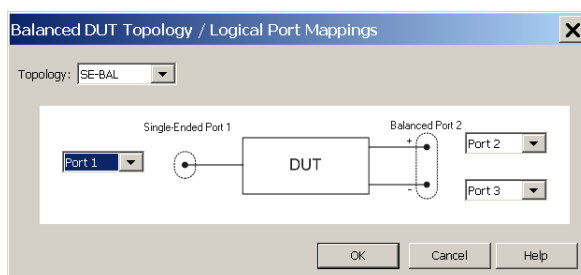

For OE measurements, the LCA sets up traces for S22, S21, S33, S31 by default.

For more information, see “Differential Measurements” on page 50.

Before you make your first opto-electrical measurement, you must initialise the OE measurement. You can see which measurement is currently initialised at the top left of the trace screen.



If you have already initialised the OE measurement, you can connect your device under test and make the measurement by pressing or .

Please refer to the user guide and online help for the network analyzer for further information.

Initializing the OE measurement

1. Press .
2. Select the “OE Measurement” tab.

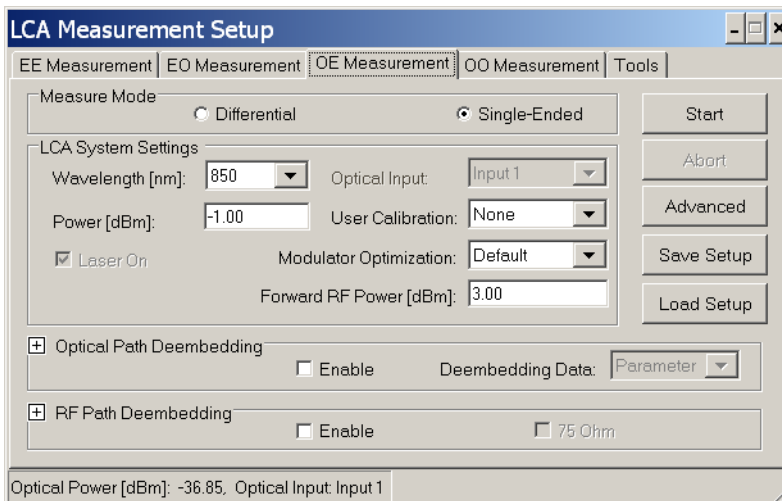

3. If necessary, select a Differential or Single-Ended Measure Mode, depending on the type of your DUT.
4. Select the wavelength at which you are testing.
5. Set the power of the Laser to be applied to the test circuit.
6. Set the forward RF power to be applied to the internal transmitter.

NOTE

The recommended settings of Forward and Reverse RF power depend on the type of measurement and your network analyzer. See “RF Power” on page 68.

If you are using a setting different from the recommended value, we recommend you also make a “User Calibration”.

7. If you are running measurements in an unstable environment, or need extra accuracy or long term stability, make sure to select “EverySweep” or “Continuous” for Modulator Optimization.

Please note, optimizing every sweep adds about 1 second to each measurement.

“Continuous” modulator bias optimization uses a 10 kHz pilot tone is applied to the signal. This improves the short and long term signal stability of the modulator working point.

The pilot tone will affect measurements with IFBW settings of the network analyzer >1.5 kHz.

For IFBW settings of the network analyzer >3 kHz we recommended you do not use “Continuous” modulator bias optimization, Use "Every Sweep" or "Once" instead.

Not using “Continuous” modulator bias optimization affects the accuracy of the internal transmitter calibration. We recommend you include a “User Calibration” in your setup (“User Calibration” on page 63) if you are not using “Continuous” modulator bias optimization.

The system is calibrated with a default setting. You can determine the default setting by going to the tools page, choosing “Default”, and pressing “Run”.

8. If you have optical components, such as attenuators, fiber optic cables or splitters, between the laser output and your device under test, open and enable the Optical Path Deembedding.

- Here you can enter the parameters for the optical path directly.

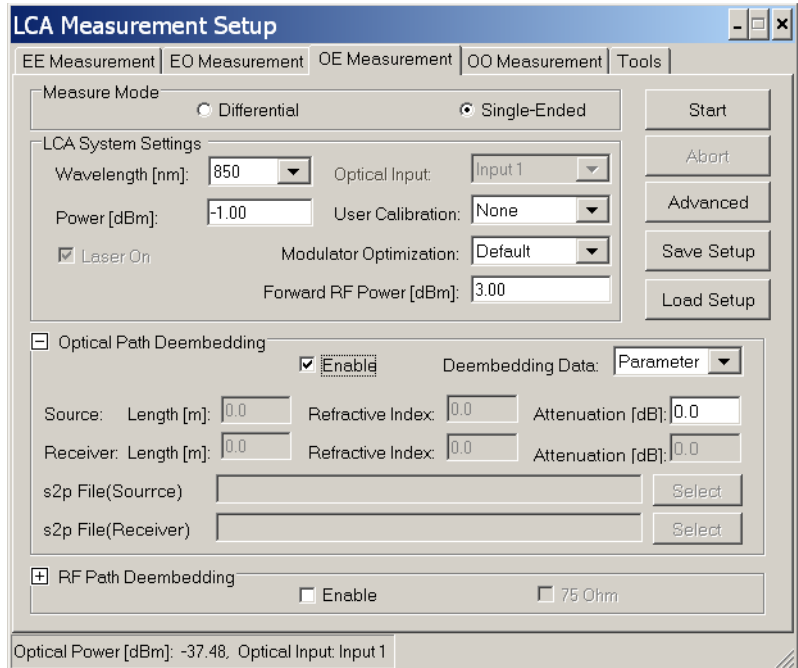

If you have already characterized the device and have a .s2p file, for “Deembedding Data”, select “File”, and enter or select the file.

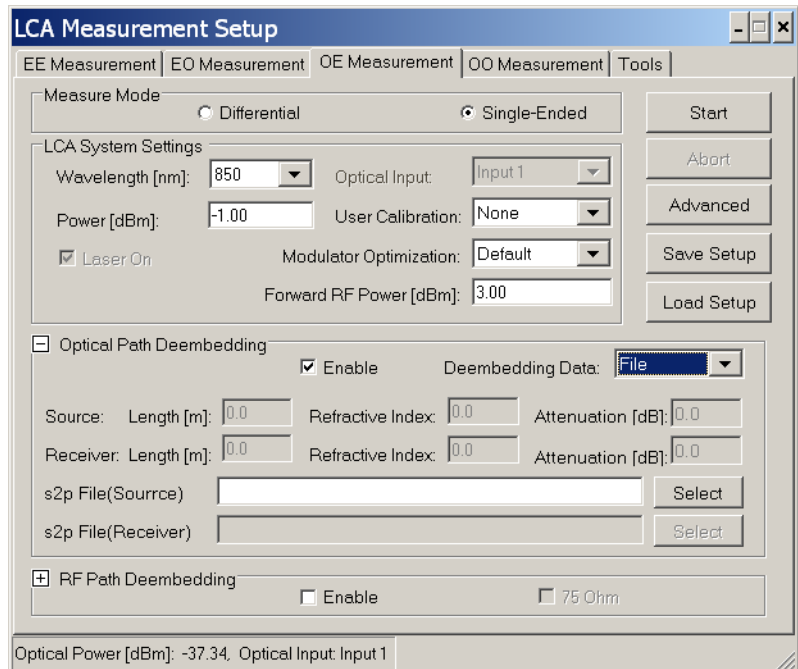

- For accurate measurements, you can also include the optical path in the test circuit without the DUT, and select “Measure” (or “Load”) for User Calibration.
10. If you have electrical components, such as RF cables, waveguide or other adapters, or probe heads, between the device under test, and the input port, open and enable the RF Path Deembedding.

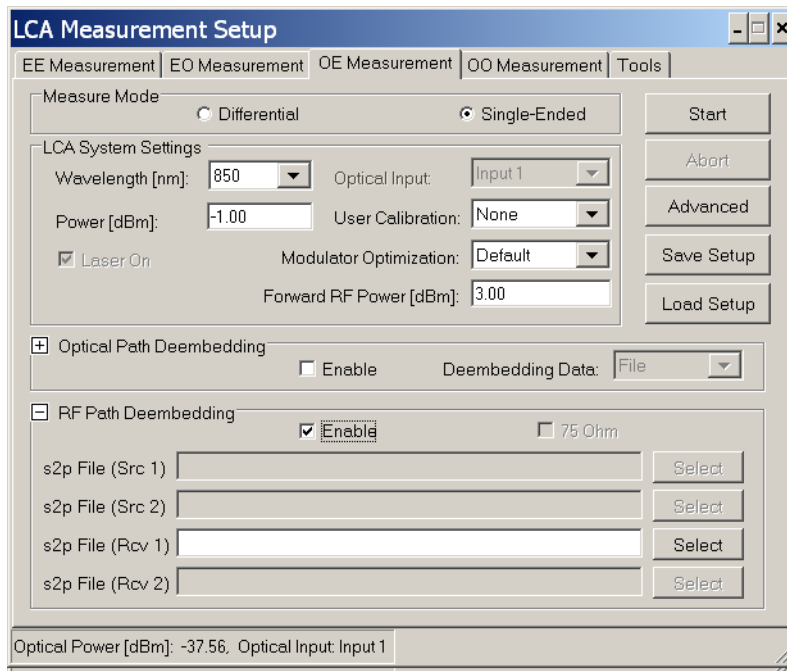

11. Enter or select the file.

12. If you are using a 75 Ω minimum loss pad, enable the RF Path Deembedding, and make sure 75 Ohm is selected.

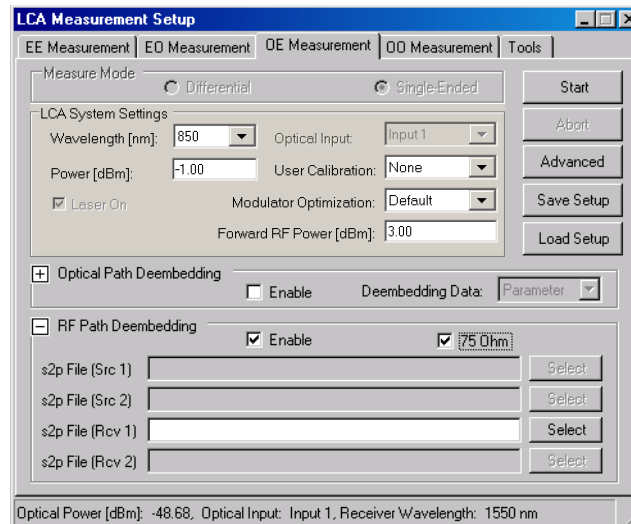

13. Enter or select the file with the characterization of the minimum loss pad.

14. Decide what sort of User Calibration you need.

- Normally, you do not need extra calibration, that is, select “None”. The LCA measures to specifications under the standard conditions.

NOTE

Optical path and electrical path deembedding is not applied during a user calibration.

- The frequency dependent transmission behavior of optical transmitters cannot be characterized as accurately as the behavior of receivers. The factory calibration ensures the uncertainty specified, but particularly for improved results at lower frequencies, this may be slightly improved by performing a user calibration. In this case, select “Measure”.
- If you want to reuse an existing, saved calibration, select “Load”, and select the file from the Windows Explorer window.

15. Click  to start the measurement preparation.

If you are performing a user calibration (“Measure”), when the following screen is displayed, make sure the optical output is connected to the optical input using the patchcord supplied.

The patchcord has the following part number:

- Multi-mode 50 μm angled/LC straight connector:
N4376D-023
- Multi-mode 62.5 μm angled/LC straight connector:
N4376D-024
- Multi-mode 50 μm angled/SC straight connector:
N4376D-025
- Multi-mode 62.5 μm angled/SC straight connector:
N4376D-026

Please also refer to the documentation supplied with the patchcord.

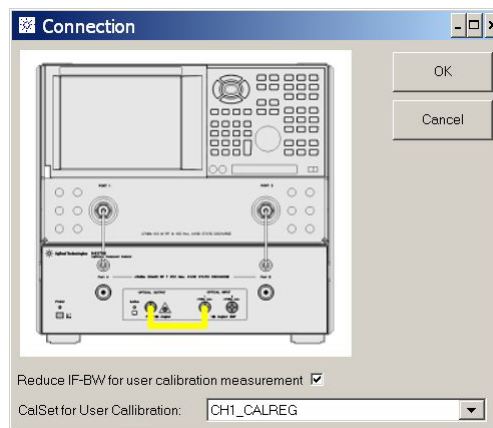



- a For the user calibration select an electrical calibration as made according to the procedure given in “Electrical calibration for “User Calibration” and OO measurements” on page 73. This calibration must have the same network analyzer settings as you are using to measure your DUT.

This electrical calibration set will only be used for the “user calibration” measurements. Afterwards the LCA returns to the original electrical calibration for the DUT measurements. The currently used calibration is preselected.

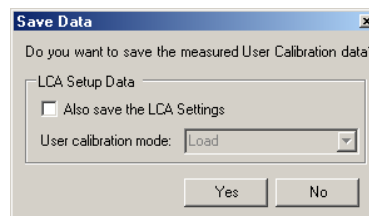
- b Select “Reduce IFBW for user calibration measurement” to reduce noise on the user calibration data. The default bandwidth reduction factor is set in the file LCAConfig.xml.
- c Click  to proceed.
- d When asked whether you want to save the data





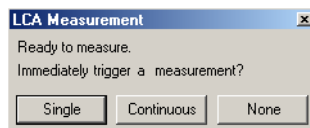

- If you can use this calibration data again, click , give your calibration data file a name, and save it. Make sure “Also save the LCA Settings” is selected if you also want to save the complete LCA setup. See “Saving and Loading Setups” on page 60 for more information about LCA setups.
- If you will have no need to reuse or refer to this calibration data, click .

Making single-ended OE measurements

1. Connect your device under test.
2. When the message is



displayed, click  or  to start the measurement.

3. To make further measurements with these settings, press  or  to start the measurement.

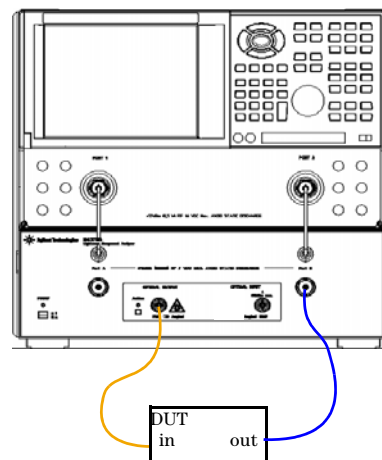

For information on further parameters, please refer to “User Interface Reference” on page 57.



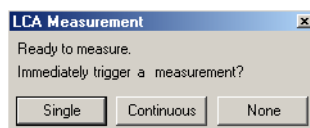

Making differential OE measurements

1. Connect your device under test.
2. When the message is



displayed, click  or  to start the measurement.

3. To make further measurements with these settings, press  or  to start the measurement.

For information on further parameters, please refer to “User Interface Reference” on page 57.

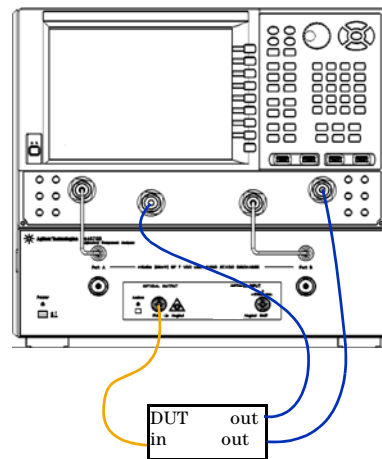

Measuring Electro-Optical (EO) Devices

Always perform an electrical calibration of the network analyzer or load an existing calibration file before you make a measurement.

For standard measurements, see “Electrical calibration for single-ended EO and OE measurements” on page 75.

For differential measurements, see “Electrical Calibration for Differential EO Measurements” on page 79.

For EO measurement the single-ended (SE), logical port 1 is assigned to physical port 4 and the balanced (BAL), logical port 2 is assigned to physical ports 2 and 3

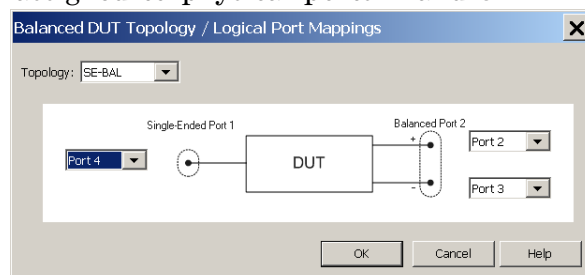

For EO measurements the LCA sets up traces for S22, S42, S33, S43 by default.

For more information, see “Differential Measurements” on page 50.

Before you make your first electro-optical measurement, you must initialise the EO measurement. You can see which measurement is currently initialised at the top left of the trace screen.



If you have already initialised the EO measurement, you can connect your device under test and make the measurement by pressing **Single** or **Continuous**.

Please refer to the user guide and online help for the network analyzer for further information.

Initializing the EO measurement

1. Press .
2. Select the “EO Measurement” tab.

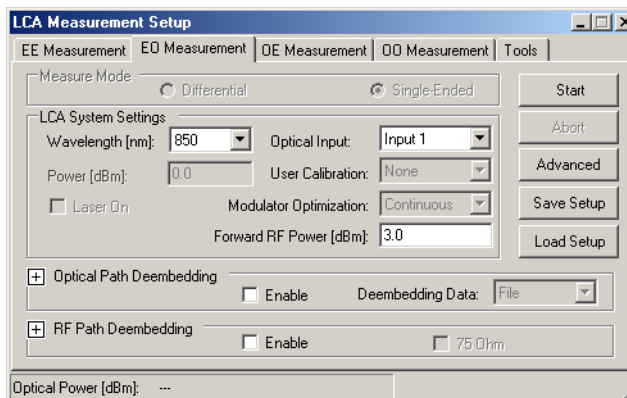

3. If necessary, select the a Differential or Single-Ended Measure Mode, depending on the type of your DUT.
4. Select or enter the wavelength at which you are testing.
5. If you have optical components, such as attenuators, fiber optic cables or splitters, between your device under test and the optical input, open and enable Optical Path Deembedding.

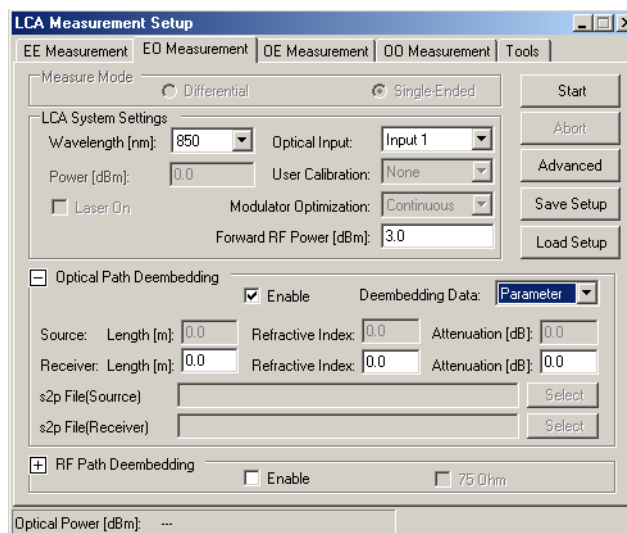

Here you can enter the parameters for the optical path directly.

Making Measurements

If you have already characterized the device and have a .s2p file, for “Deembedding Data”, select “File”, and enter or select the file.

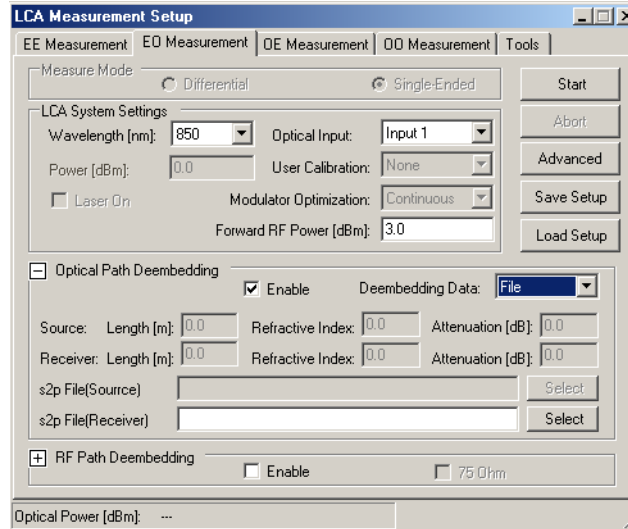

6. If you have electrical components, such as RF cables, waveguide or other adapters, or probe heads, between the output port and your device under test, open and enable the RF Path Deembedding.

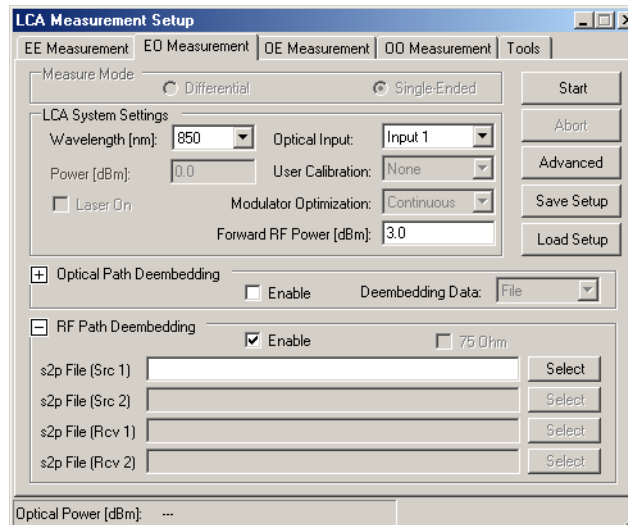

7. Enter or select the file.
8. If you are using a 75 Ω minimum loss pad, enable the RF Path Deembedding, and make sure 75 Ohm is selected.

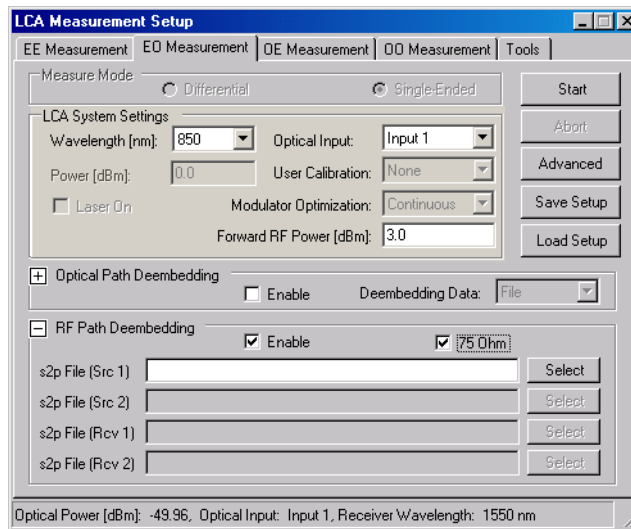



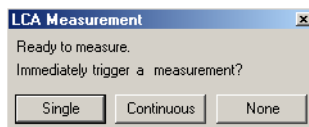

9. Enter or select the file with the characterization of the minimum loss pad.
10. Click  to start the measurement preparation.

Making single-ended EO measurements

1. Connect your device under test.
2. When the message is



displayed, click  or  to start the measurement.

3. To make further measurements with these settings, press  or  to start the measurement.

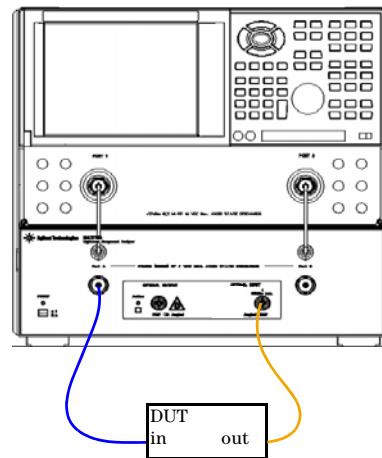

For information on further parameters, please refer to “User Interface Reference” on page 57.

Making differential EO measurements

1. Connect your device under test.
2. When the message is

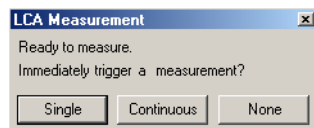

displayed, click or to start the measurement.

3. To make further measurements with these settings, press or to start the measurement.

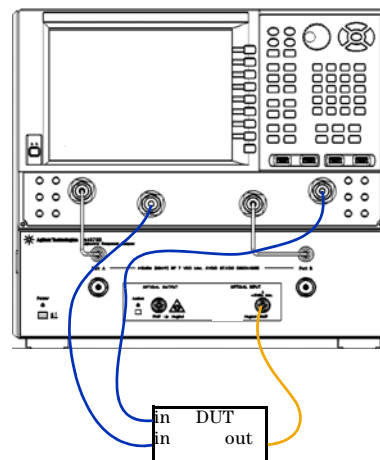

For information on further parameters, please refer to “User Interface Reference” on page 57.

Returning to Electrical Measurements

Before you measure purely electrical devices with the network analyzer, you need to initialize EE measurements. Returning to EE measurements is also needed before doing an electrical calibration.

Initializing the EE Measurement as described here removes all the fixturing information in the network analyzer that is specific to the optical test set. The internal RF switches are also switched to the "Thru" position, and the RF power on all ports is set to the power specified for “Reverse RF Power [dBm]”

NOTE

The recommended settings of Forward and Reverse RF power depend on the type of your network analyzer. See “RF Power” on page 68.

1. Press .

2. Make sure the “EE Measurement” tab is selected.

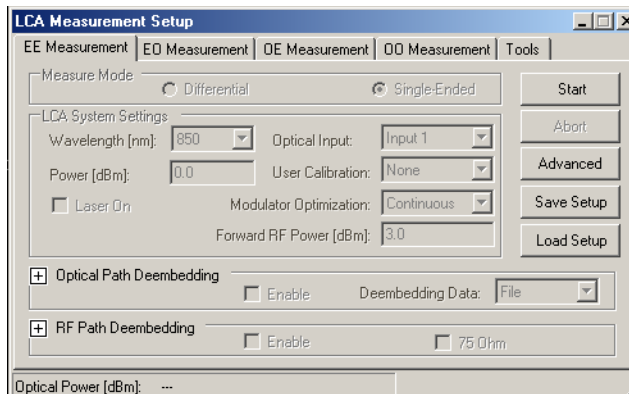

3. Click .



Measuring Optical-Optical (OO) Devices

Always perform an electrical calibration of the network analyzer or load an existing calibration set before you make a measurement.

For standard measurements, see “Electrical calibration for single-ended EO and OE measurements” on page 75.

Before you make your first optical-optical measurement, you must initialise the OO measurement. You can see which measurement is currently initialised at the top left of the trace screen.



If you have already initialised the OO measurement, you can connect your device under test and make the measurement by pressing  or .

Please refer to the user guide and online help for the network analyzer for further information.

Initializing the OO measurement

1. Click .
2. Select the “OO Measurement” tab.

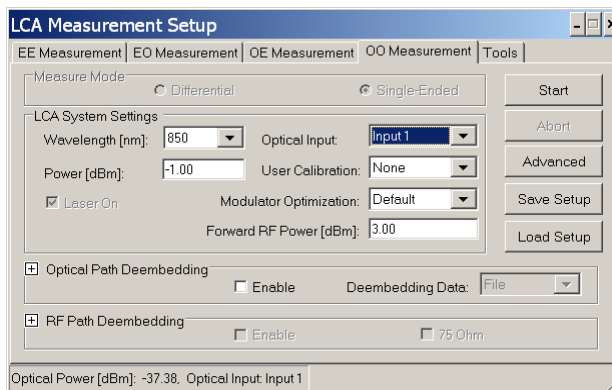

3. Select the wavelength at which you are testing.
4. Set the power of the Laser to be applied to the test circuit.
5. If you are running measurements in an unstable environment, or need extra accuracy or long term stability, make sure to select “EverySweep” or “Continuous” for Modulator Optimization.

Please note, optimizing every sweep adds about 1 second to each measurement. Continuous optimization uses a pilot tone. Measuring with or without the pilot tone may affect your measurement.

We also recommend, if you are using continuous optimization, that you also perform a “User Calibration”.

The system is calibrated with a default setting. You can determine the default setting by going to the tools page, choosing “Default”, and pressing “Run”.

6. If you have optical components, such as attenuators, fiber optic cables or splitters, between the optical input and output and your device under test, open and enable the Optical Path Deembedding.

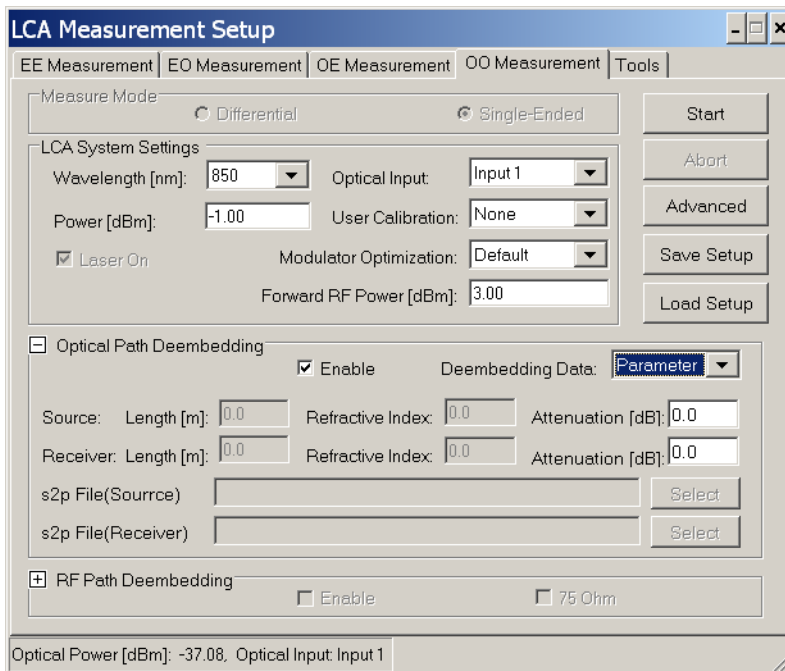

Here you can enter the parameters for the optical path directly.

If you have already characterized the device and have a .s2p file, for “Deembedding Data”, select “File”, and enter or select the file.

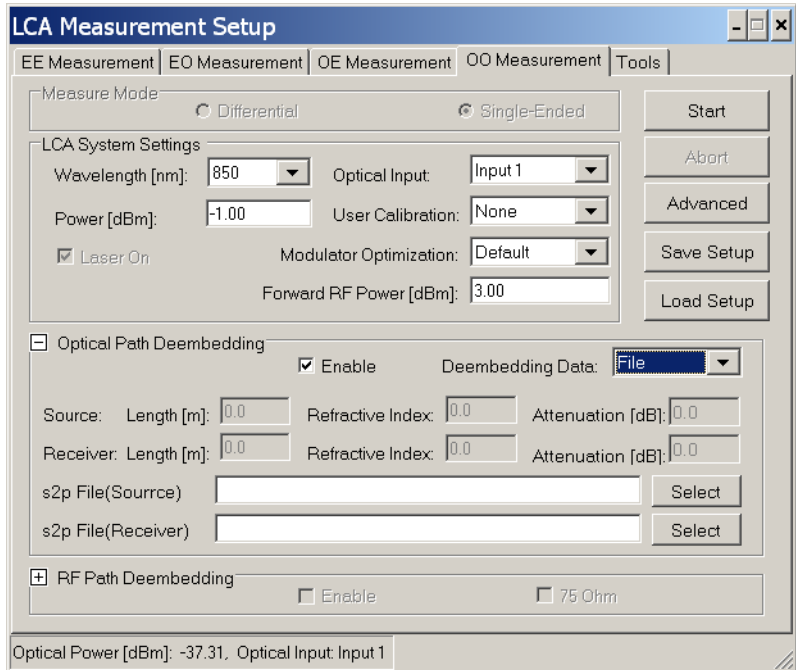

- For accurate measurements, you can also include the optical path in the test circuit without the DUT, and select “Measure” (or “Load”) for User Calibration.
7. Decide what sort of calibration you need.
 - If for “User Calibration”, you select “None”, the LCA uses the factory default calibration.

NOTE

Optical path and electrical path deembedding is not applied during a user calibration.

- The factory calibration ensures the uncertainty specified, but particularly for improved results at lower frequencies, we recommend an extra calibration. In this case, for “User Calibration”, select “Measure”.
 - If you want to reuse an existing, saved calibration, for “User Calibration”, select “Load”, and select the file from the Windows Explorer window.
8. Click  to start the measurement preparation.

If you are calibrating, when the following screen is displayed, make sure the optical output is connected to the optical input using the patchcord supplied.

The patchcord has the following part number:

- Multi-mode 50 μm angled/LC straight connector:
N4376D-023
- Multi-mode 62.5 μm angled/LC straight connector:
N4376D-024
- Multi-mode 50 μm angled/SC straight connector:
N4376D-025
- Multi-mode 62.5 μm angled/SC straight connector:
N4376D-026

Please also refer to the documentation supplied with the patchcord.

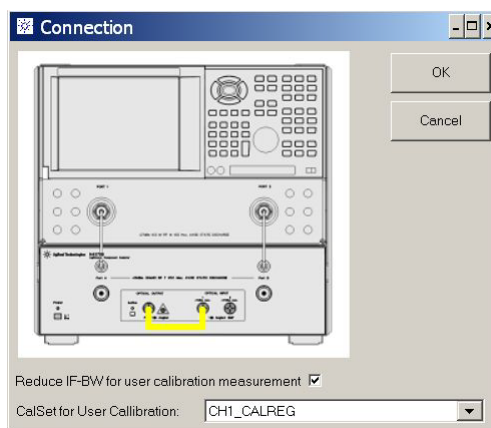

- a For the user calibration select an electrical calibration as made according to the procedure given in “Electrical calibration for “User Calibration” and OO measurements” on page 73.

This calibration must have the same network analyzer settings as you are using to measure your DUT.

This will only be used for the “user calibration” measurements. Afterwards the LCA returns to the original electrical calibration for the DUT measurements.

The currently used calibration is preselected.

- b Select “Reduce IFBW for user calibration measurement” to reduce noise on the user calibration data. The default bandwidth reduction factor is set in the file LCAConfig.xml.
- c Click  to proceed.
- d When asked whether you want to save the data

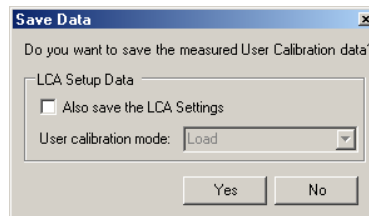

- If you can use this calibration data again, click , give your calibration data file a name, and save it.

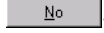

If you want to save the complete LCA setup, make sure to select “Also save the LCA Settings” . See “Saving and Loading Setups” on page 60 for more information about LCA setups.

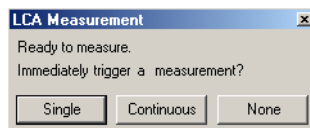

- If you will have no need to reuse or refer to this calibration data, click .

Making OO measurements

1. Connect your device under test.
2. When the message is



displayed, click  or  to start the measurement.

3. To make further measurements with these settings, press  or  to start the measurement.

For information on further parameters, please refer to “User Interface Reference” on page 57

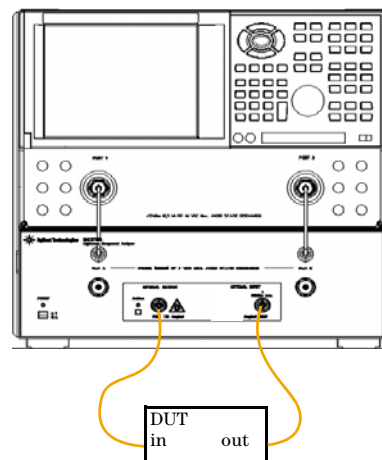

Measuring Optical Power

Press , to measure the average optical power.

Making Measurements

7 Maintenance

Cleaning 104
Replacing the Fuse 119

This system should be serviced only by authorized personnel.

WARNING

Using controls or adjustments or performing procedures other than those specified in the documentation supplied with your equipment can result in hazardous radiation exposure.

Cleaning

Safety precautions

The following cleaning instructions contain some general safety precautions, which must be observed during all phases of cleaning.

Please try, whenever possible, to use physically contacting connectors, and dry connections. Clean the connectors, interfaces, and bushings carefully after use.

If you are unsure of the correct cleaning procedure for your optical device, we recommend that you first try cleaning a dummy or test device.

Agilent Technologies assumes no liability for the customer is failure to comply with these requirements.

WARNING

Please follow the following safety rules.

Do not remove instrument covers when operating.

Ensure that the instrument is switched off throughout the cleaning procedures.

Use of controls or adjustments or performance of procedures other than those specified may result in hazardous radiation exposure.

Make sure that you disable all sources when you are cleaning any optical interfaces.

Under no circumstances look into the end of an optical device attached to optical outputs when the device is operational. The laser radiation is not visible to the human eye, but it can seriously damage your eyesight.

To prevent electrical shock, disconnect the instrument from the mains before cleaning. Use a dry cloth, or one slightly dampened with water, to clean the external case parts. Do not attempt to clean internally.

Do not install parts or perform any unauthorized modification to optical devices.

Refer servicing only to qualified and authorized personnel.

Why is it important to clean optical devices?

In transmission links optical fiber cores are about 9 μm (0.00035") in diameter. Dust and other particles, however, can range from tenths to hundredths of microns in diameter. Their comparative size means that they can cover a part of the end of a fiber core, and thus degrade the transmission quality. This will reduce the performance of your system.

Furthermore, the power density may burn dust into the fiber and cause additional damage (for example, 0 dBm optical power in a single mode fiber causes a power density of approximately 16 million W/m^2). If this happens, measurements become inaccurate and non-repeatable.

Cleaning is, therefore, an essential yet difficult task. Unfortunately, when comparing most published cleaning recommendations, you will discover that they contain several inconsistencies. We want to suggest ways to help you clean your various optical devices, and thus significantly improve the accuracy and repeatability of your lightwave measurements.

What do I need for proper cleaning?

Standard cleaning equipment

Before you can start your cleaning procedure you need the following standard equipment:

- Dust and shutter caps
- Isopropyl alcohol
- Cotton swabs
- Soft tissues
- Pipe cleaner
- Compressed air

Dust and shutter caps All Agilent Technologies lightwave instruments are delivered with either laser shutter caps or dust caps on the lightwave adapter. Any cables come with covers to protect the cable ends from damage or contamination.

We suggest these protective coverings should be kept on the equipment at all times, except when your optical device is in use. Be careful when replacing dust caps after use. Do not press the bottom of the cap onto the fiber too hard, as any dust in the cap can scratch or pollute your fiber surface.

If you need further dust caps, please contact your nearest Agilent Technologies sales office.

Isopropyl alcohol This solvent is usually available from any local pharmaceutical supplier or chemist's shop.

If you use isopropyl alcohol to clean your optical device, do not immediately dry the surface with compressed air (except when you are cleaning very sensitive optical devices). This is because the dust and the dirt is solved and will leave behind filmy deposits after the alcohol is evaporated. You should therefore first remove the alcohol and the dust with a soft tissue, and then use compressed air to blow away any remaining filaments.

If possible avoid using denatured alcohol containing additives. Instead, apply alcohol used for medical purposes. Never drink this alcohol, as it may seriously damage to your health.

Do not use any other solvents, as some may damage plastic materials and claddings. Acetone, for example, will dissolve the epoxy used with fiber optic connectors. To avoid damage, only use isopropyl alcohol.

Cotton swabs We recommend that you use swabs such as Q-tips or other cotton swabs normally available from local distributors of medical and hygiene products (for example, a supermarket or a chemist's shop). You may be able to obtain various sizes of swab. If this is the case, select the smallest size for your smallest devices.

Ensure that you use natural cotton swabs. Foam swabs will often leave behind filmy deposits after cleaning.

Use care when cleaning, and avoid pressing too hard onto your optical device with the swab. Too much pressure may scratch the surface, and could cause your device to become misaligned.

It is advisable to rub gently over the surface using only a small circular movement.

Swabs should be used straight out of the packet, and never used twice. This is because dust and dirt in the atmosphere, or from a first cleaning, may collect on your swab and scratch the surface of your optical device.

Soft tissues These are available from most stores and distributors of medical and hygiene products such as supermarkets or chemists' shops.

We recommend that you do not use normal cotton tissues, but multi-layered soft tissues made from non-recycled cellulose. Cellulose tissues are very absorbent and softer. Consequently, they will not scratch the surface of your device over time.

Use care when cleaning, and avoid pressing on your optical device with the tissue. Pressing too hard may lead to scratches on the surface or misalignment of your device.

Just rub gently over the surface using a small circular movement.

Use only clean, fresh soft tissues and never apply them twice. Any dust and dirt from the air which collects on your tissue, or which has gathered after initial cleaning, may scratch and pollute your optical device.

Pipe cleaner Pipe cleaners can be purchased from tobacconists, and come in various shapes and sizes. The most suitable one to select for cleaning purposes has soft bristles, which will not produce scratches.

The best way to use a pipe cleaner is to push it in and out of the device opening (for example, when cleaning an interface). While you are cleaning, you should slowly rotate the pipe cleaner.

Only use pipe cleaners on connector interfaces or on feedthrough adapters. Do not use them on optical head adapters, as the center of a pipe cleaner is hard metal and can damage the bottom of the adapter.

Your pipe cleaner should be new when you use it. If it has collected any dust or dirt, this can scratch or contaminate your device.

The tip and center of the pipe cleaner are made of metal. Avoid accidentally pressing these metal parts against the inside of the device, as this can cause scratches.

Compressed air Compressed air can be purchased from any laboratory supplier.

It is essential that your compressed air is free of dust, water and oil. Only use clean, dry air. If not, this can lead to filmy deposits or scratches on the surface of your connector. This will reduce the performance of your transmission system.

When spraying compressed air, hold the can upright. If the can is held at a slant, propellant could escape and dirty your optical device. First spray into the air, as the initial stream of compressed air could contain some condensation or propellant. Such condensation leaves behind a filmy deposit.

Please be friendly to your environment and use a CFC-free aerosol.

Additional cleaning equipment

Some Cleaning Procedures need the following equipment, which is not required to clean each instrument:

- Microscope with a magnification range about 50X up to 300X
- Ultrasonic bath
- Warm water and liquid soap
- Premoistened cleaning wipes
- Lens papers
- Polymer film
- Infrared Sensor Card

Microscope with a magnification range about 50X up to 300X

A microscope can be found in most photography stores, or can be obtained through or specialist mail order companies. Special fiber-scopes are available from suppliers of splicing equipment.

Ideally, the light source on your microscope should be very flexible. This will allow you to examine your device closely and from different angles.

A microscope helps you to estimate the type and degree of dirt on your device. You can use a microscope to choose an appropriate cleaning method, and then to examine the results. You can also use your microscope to judge whether your optical device (such as a connector) is severely scratched and is, therefore, causing inaccurate measurements.

Ultrasonic bath Ultrasonic baths are also available from laboratory suppliers or specialist mail order companies.

An ultrasonic bath will gently remove fat and other stubborn dirt from your optical devices. This helps increase the life span of the optical devices.

Only use isopropyl alcohol in your ultrasonic bath, as other solvents may cause damage.

Warm water and liquid soap Only use water if you are sure that there is no other way of cleaning your optical device without causing corrosion or damage. Do not use water that is too hot or too cold, as this may cause mechanical stress, which can damage your optical device.

Ensure that your liquid soap has no abrasive properties or perfume in it. You should also avoid normal washing-up liquid, as it can cover your device in an iridescent film after it has been air-dried.

Some lenses and mirrors also have a special coating, which may be sensitive to mechanical stress, or to fat and liquids. For this reason we recommend you do not touch them.

If you are not sure how sensitive your device is to cleaning, please contact the manufacturer or your sales distributor.

Premoistened cleaning wipes Use pre-moistened cleaning wipes as described in each individual cleaning procedure. Cleaning wipes may be used in every instance where a moistened soft tissue or cotton swab is applied.

Lens cleaning papers Some special lens cleaning papers are not suitable for cleaning optical devices like connectors, interfaces, lenses, mirrors and so on. To be absolutely certain that a cleaning paper is applicable, please ask the salesperson or the manufacturer.

Polymer film Polymer film is available from laboratory suppliers or specialist mail order companies.

Using polymer film is a gentle method of cleaning extremely sensitive devices, such as reference reflectors and mirrors.

Infrared sensor card Infrared sensor cards are available from laboratory suppliers or specialist mail order companies.

With this card you are able to control the shape of laser light emitted. The invisible laser beam is projected onto the sensor card, then becomes visible to the normal eye as a round spot.

WARNING

Take care never to look into the end of a fiber or any other optical component when they are in use. This is because the laser can seriously damage your eyes.

Preserving connectors

Listed below are some hints on how best to keep your connectors in the best possible condition.

Making connections

Before you make any connection you must ensure that all cables and connectors are clean. If they are dirty, use the appropriate cleaning procedure.

When inserting the ferrule of a patchcord into a connector or an adapter, make sure that the fiber end does not touch the outside of the mating connector or adapter. Otherwise you will rub the fiber end against an unsuitable surface, producing scratches and dirt deposits on the surface of your fiber.

Dust caps and shutter caps

Be careful when replacing dust caps after use. Do not press the bottom of the cap onto the fiber as any dust in the cap can scratch or dirty your fiber surface.

When you have finished cleaning, put the dust cap back on, or close the shutter cap if the equipment is not going to be used immediately.

Always keep the caps on the equipment when it is not in use.

All Agilent Technologies lightwave instruments and accessories are shipped with either laser shutter caps or dust caps. If you need additional or replacement dust caps, contact your nearest Agilent Technologies Sales/Service Office.

Immersion oil and other index matching compounds

Wherever possible, do not use immersion oil or other index matching compounds with your device. They are liable to impair and dirty the surface of the device. In addition, the characteristics of your device can be changed and your measurement results affected.

Cleaning instrument housings

WARNING

Do not open the instruments as there is a danger of electric shock, or electrostatic discharge.

CAUTION

Do not open instruments. Opening the instrument can cause damage to sensitive components, and in addition your warranty will be voided.

CAUTION

Do not use isopropyl alcohol to clean instrument housings.

Use a dry and very soft cotton tissue to clean the instrument housing and the keypad. In the case of heavy dirt, you can moisten the cotton tissue in water.

Which cleaning procedure should I use for optical components and connectors?

Light dirt

If you just want to clean away light dirt, observe the following procedure for all devices.

- Use compressed air to blow away large particles.
- Clean the device with a dry cotton swab.

- Use compressed air to blow away any remaining filament left by the swab.

Heavy dirt

If the above procedure is not enough to clean your instrument, follow one of the procedures below.

If you are unsure of how sensitive your device is to cleaning, please contact the manufacturer or your sales distributor.

How to clean connectors

Cleaning connectors is difficult, as the core diameter of a single-mode fiber is only about $9\mu\text{m}$. This generally means you cannot see streaks or scratches on the surface. To be certain of the condition of the surface of your connector and to check it after cleaning, you need a microscope.

In the case of scratches, or of dust that has been burnt onto the surface of the connector, you may have no option but to polish the connector. This depends on the degree of dirtiness, or the depth of the scratches. This is a difficult procedure and should only be performed by a skilled person, and as a last resort, as it wears out your connector.

WARNING

Never look into the end of an optical cable that is connected to an active source.

To assess the projection of the emitted light beam you can use an infrared sensor card. Hold the card approximately 5 cm from the output of the connector. The invisible emitted light is projected onto the card and becomes visible as a small circular spot.

Preferred procedure Use the following procedure on most occasions.

1. Clean the connector by rubbing a new, dry cotton swab over the surface using a small circular movement.
2. Blow away any remaining lint with compressed air.

Procedure for stubborn dirt Use this procedure when there is greasy dirt on the connector.

1. Moisten a new cotton swab with isopropyl alcohol.

2. Clean the connector by rubbing the cotton swab over the surface using a small circular movement.
3. Take a new, dry soft tissue and remove the alcohol, dissolved sediment and dust, by rubbing gently over the surface using a small circular movement.
4. Blow away any remaining lint with compressed air.

Alternative procedure A better, more gentle, but more expensive cleaning procedure is to use an ultrasonic bath with isopropyl alcohol.

1. Hold the tip of the connector in the bath for at least three minutes.
2. Take a new, dry soft tissue and remove the alcohol, dissolved sediment and dust, by rubbing gently over the surface using a small circular movement.
3. Blow away any remaining lint with compressed air.

How to clean connector interfaces

CAUTION

Be careful when using pipe cleaners, as the core and the bristles of the pipe cleaner are hard and can damage the interface.

Preferred procedure Use the following procedure on most occasions.

1. Clean the interface by pushing and pulling a new, dry pipe cleaner into the opening. Rotate the pipe cleaner slowly as you do this.
2. Blow away any remaining lint with compressed air.

Procedure for stubborn dirt Use this procedure when there is greasy dirt on the interface.

1. Moisten a new pipe cleaner with isopropyl alcohol.
2. Clean the interface by pushing and pulling the pipe cleaner into the opening. Rotate the pipe cleaner slowly as you do this.
3. Moisten a new cotton swab with isopropyl alcohol.

4. Using a new, dry pipe cleaner, remove the alcohol, any dissolved sediment and dust.
5. Blow away any remaining lint with compressed air.

How to clean bare fiber adapters

Bare fiber adapters are difficult to clean. Protect from dust unless they are in use.

CAUTION

Never use any kind of solvent when cleaning a bare fiber adapter as solvents can:

- damage the foam inside some adapters;
 - deposit dissolved dirt in the groove, which can then dirty the surface of an inserted fiber.
-

Preferred procedure Use the following procedure on most occasions.

1. Blow away any dust or dirt with compressed air.

Procedure for stubborn dirt Use this procedure when there is greasy dirt on the adapter.

CAUTION

Be careful when using pipe cleaners, as the core and the bristles of the pipe cleaner are hard and can damage the adapter.

1. Clean the adapter by pushing and pulling a new, dry pipe cleaner into the opening. Rotate the pipe cleaner slowly as you do this.
2. Clean the adapter by rubbing a new, dry cotton swab over the surface using a small circular movement.
3. Blow away any remaining lint with compressed air.

How to clean lenses

Some lenses have special coatings that are sensitive to solvents, grease, liquid and mechanical abrasion. Take extra care when cleaning lenses with these coatings.

Lens assemblies consisting of several lenses are not normally sealed. Therefore, use as little alcohol as possible, as it can get between the lenses and in doing so can change the properties of projection.

Preferred procedure Use the following procedure on most occasions.

1. Clean the lens by rubbing a new, dry cotton swab over the surface using a small circular movement.
2. Blow away any remaining lint with compressed air.

Procedure for stubborn dirt Use this procedure when there is greasy dirt on the lens.

1. Moisten a new cotton swab with isopropyl alcohol.
2. Clean the lens by rubbing the cotton swab over the surface using a small circular movement.
3. Using a new, dry cotton swab remove the alcohol, any dissolved sediment and dust.
4. Blow away any remaining lint with compressed air.

How to clean instruments with a fixed connector interface

You should only clean instruments with a fixed connector interface when it is absolutely necessary. This is because it is difficult to remove any used alcohol or filaments from the input of the optical block.

It is important, therefore, to keep dust caps on the equipment at all times, except when your optical device is in use.

CAUTION

Only use clean, dry compressed air. Make sure that the air is free of dust, water, and oil. If the air that you use is not clean and dry, this can lead to filmy deposits or scratches on the surface of your connector interface. This will degrade the performance of your transmission system.

Never try to open the instrument and clean the optical block by yourself, because it is easy to scratch optical components, and cause them to become misaligned.

If you do discover filaments or particles, the only way to clean a fixed connector interface and the input of the optical block is to use compressed air.

If there are fluids or oil in the connector, please refer the instrument to the skilled personnel of the Agilent service team.

How to clean instruments with a physical contact interface

Remove any connector interfaces from the optical output of the instrument before you begin the cleaning procedure.

Cleaning interfaces is difficult as the core diameter of a single-mode fiber is only about 9 μm . This generally means you cannot see streaks or scratches on the surface. To be certain of the degree of pollution on the surface of your interface and to check whether it has been removed after cleaning, you need a microscope.

WARNING

Never look into an optical output, because this can seriously damage your eyesight.

To assess the projection of the emitted light beam you can use an infrared sensor card. Hold the card approximately 5 cm from the interface. The invisible emitted light is projected onto the card and becomes visible as a small circular spot.

Preferred procedure Use the following procedure on most occasions.

1. Clean the interface by rubbing a new, dry cotton swab over the surface using a small circular movement.
2. Blow away any remaining lint with compressed air.

Procedure for stubborn dirt Use this procedure when there is greasy dirt on the interface.

1. Moisten a new cotton swab with isopropyl alcohol.
2. Clean the interface by rubbing the cotton swab over the surface using a small circular movement.
3. Take a new, dry soft tissue and remove the alcohol, dissolved sediment and dust, by rubbing gently over the surface using a small circular movement.

4. Blow away any remaining lint with compressed air.

How to clean instruments with a recessed lens interface

For instruments with a deeply recessed lens interface (for example the Agilent Technologies 81633A and 81634A Power Sensors) do NOT follow this procedure. Alcohol and compressed air could damage your lens even further.

Keep your dust and shutter caps on when your instrument is not in use. This should prevent it from getting too dirty.

If you must clean such instruments, please refer the instrument to the skilled personnel of the Agilent service team.

Preferred procedure Use the following procedure on most occasions.

1. Blow away any dust or dirt with compressed air.

If this is not sufficient, then

- a. Clean the interface by rubbing a new, dry cotton swab over the surface using a small circular movement.
- b. Blow away any remaining lint with compressed air.

Procedure for stubborn dirt Use this procedure when there is greasy dirt on the interface, and using the procedure for light dirt is not sufficient.

Using isopropyl alcohol should be your last choice for recessed lens interfaces because of the difficulty of cleaning out any dirt that is washed to the edge of the interface.

1. Moisten a new cotton swab with isopropyl alcohol.
2. Clean the interface by rubbing the cotton swab over the surface using a small circular movement.
3. Take a new, dry soft tissue and remove the alcohol, dissolved sediment and dust, by rubbing gently over the surface using a small circular movement.
4. Blow away any remaining lint with compressed air.

How to clean optical devices which are sensitive to mechanical stress and pressure

Some optical devices, such as Reference Reflectors, are very sensitive to mechanical stress or pressure. Do not use cotton swabs, soft tissues or other mechanical cleaning tools, as these can scratch or destroy the surface.

Preferred procedure Use the following procedure on most occasions.

1. Blow away any dust or dirt with compressed air.

Procedure for stubborn dirt To clean devices that are extremely sensitive to mechanical stress or pressure you can also use an optical clean polymer film. This procedure is time-consuming, but you avoid scratching or destroying the surface.

1. Put the film on the surface and wait at least 30 minutes to make sure that the film has had enough time to dry.
2. Remove the film and any dirt with special adhesive tapes.

Alternative procedure For these types of optical devices you can often use an ultrasonic bath with isopropyl alcohol. Only use the ultrasonic bath if you are sure that it won't cause any damage to any part of the device.

1. Put the device into the bath for at least three minutes.
2. Blow away any remaining liquid with compressed air.

If there are any streaks or drying stains on the surface, repeat the cleaning procedure.

How to clean bare fiber ends

Bare fiber ends are often used for splices or, together with other optical components, to create a parallel beam.

The end of a fiber can often be scratched. You make a new cleave. To do this:

1. Strip off the cladding.
2. Take a new soft tissue and moisten it with isopropyl alcohol.
3. Carefully clean the bare fiber with this tissue.

4. Make your cleave and immediately insert the fiber into your bare fiber adapter in order to protect the surface from dirt.

Replacing the Fuse



(1)

1. On the rear of the optical test set, use a flat-tipped screwdriver to lever open the fuse holder from underneath (1).
2. Pull the fuse holder and fuse clear of the back panel.
3. Take the fuse out of the fuse cap and note the fuse rating.
4. Make sure the replacement fuse has the same rating (T1A, 250V, Agilent part number 2110-0007).
5. Put the fuse into the fuse holder.
6. Put the fuse and fuse cap into the receptacle in the rear of the case and press it into place.

Maintenance

8

Troubleshooting

Checking the Operation of the Lightwave Component Analyzer 122
 Event Log 122

This system should be serviced only by authorized personnel.

WARNING Using controls or adjustments or performing procedures other than those specified in the documentation supplied with your equipment can result in hazardous radiation exposure.

Checking the Operation of the Lightwave Component Analyzer

1. Shut down the network analyzer, as described in the network analyzer user guide and online help.
2. Power down both the network analyzer and the optical test set.
3. Start the equipment and perform an electrical calibration of the network analyzer, as described in “Starting the Lightwave Component Analyzer” on page 72.
4. Perform the performance verification, as described in “Performance Quick Check” on page 31.

Event Log

Further troubleshooting information is available from the event log.

You can find this log in the \bin subdirectory of the directory where the LCA program is installed.

If you want to refer to the log, save a copy of it before you restart the LCA server. The log file is cleared each time the LCA server is restarted.

If you have a problem with the LCA, you can also send the event log file to your Agilent contact person to speed up diagnosis.

9

Reinstalling and Updating the Software

Backing Up your LCA Data	124
Reinstalling the LCA Software	124

Backing Up your LCA Data

The information for your particular configuration of the LCA and the factory calibration data are kept in the “Table” and “Information” subdirectories of the directory in which the software is installed.

These two directories are backed up under the "LCA" directory on the "D" drive of your network analyzer. These directories are not overwritten when performing the network analyzer's system recovery process.

Please refer to the user documentation of the network analyzer for information on backing up calibration data.

Reinstalling the LCA Software

There are two cases:

- Updating the LCA software.
- Reinstalling the LCA software completely, for example after recovering the network analyzer

Updating the LCA software

1. Before updating the software, you must remove the existing software.
 - a In Windows' Settings, go to the Control Panel and select Add or Remove Programs.
 - b Select the LCA application from the list of programs.
 - c Remove the program.
2. Start the LCA setup software **LCAInstaller.msi**.
3. Follow the instructions on the screen.

We recommend you use the default settings.

Reinstalling the LCA software

Pre-installing the framework and drivers

Before reconnecting the optical test set to the network analyzer (that is, with the USB cable disconnected or before powering up the optical test set), you need to pre-install the USB drivers.

1. On the CD-ROM supplied with the LCA, in the directory **\Reinstallation\USB Driver**, start the driver installation software **USB Setup.exe**.

When the setup dialog closes, the pre-installation is finished.

2. Make sure the optical test set is connected by USB to the network analyzer.
3. Turn on the power of the optical test set.

The network analyzer will find the new hardware and will finish the installation of the drivers.

When asked if windows should connect to “Windows Update”, answer “No, not this time”.

In the next step of the “Found New Hardware Wizard” you are asked what you want the wizard to do. Select “Install the software automatically” since you already finished the USB driver pre-installation.

This happens twice, once for each port (Port A and Port B) of the optical test set.

Reinstalling the software

1. On the CD-ROM supplied with the LCA, in the directory **\Reinstallation\LCA Software**, start the LCA setup software **Setup.exe**.
2. Follow the instructions on the screen.

We recommend you use the default settings.

Note the directory to which the LCA application is installed.

3. The registry script in the next step installs LCA related functions in the first 5 positions of the network analyzers macro setup.

Existing macros will be overwritten.

To prevent this, make sure that the first five positions are empty. You can do this in the network analyzers macro setup dialog:

“System\Macro\Macro Setup”.

In this dialog move down all existing macros, so that the first five positions are empty.

4. In this LCA directory, right click on the file **NWAShortcuts.reg**.
5. From the context menu, select **Merge**.



Restoring the hardware calibration files

1. On the network analyzers “D” drive, open the directory “LCA”.
2. Copy all folders (with all their subfolders) into the LCA installation directory:
3. “C:\Program Files\Agilent\LCA”. (default directory).

Starting the LCA Server

NOTE

When starting the “LCA Measurement Setup” with no server running, the server is started automatically.

1. Run the network analyzer.
2. Double-click on the “LCA Server” shortcut on the Desktop of the network analyzer.
3. Or start the LCA server by pressing .
4. Press .

10

Definition of Terms

Definition of Terms.....128

Definition of Terms

Absolute frequency response uncertainty

The maximum difference between measured [Responsivity](#) of a device under test and the actual (true) responsivity, expressed in dBe.

Conditions: as specified.

NOTE

Any change in the cabling after calibration add to the specified absolute frequency response uncertainty.

Measurement: Based on a reference RF O/E receiver.

Average output power (optical)

The (actual or nominal) average output power from the LCA optical output.

Average output power range (optical)

The nominal (selectable) range for [Average output power \(optical\)](#).

Average output power stability (optical)

The variation of the optical [Average output power \(optical\)](#) P over time, calculated as

$$\pm \frac{\max_t\{P(t)\} - \min_t\{P(t)\}}{2}$$

where $\max_t\{\}$ and $\min_t\{\}$ are the maximum and minimum value over time t .

Conditions: Time period as specified after modulator auto bias (“modulator optimization”) is performed with the selected wavelength. Other conditions as specified.

Measurement: Using an average power meter with averaging time set to 1 s.

Average output power uncertainty (optical)

The maximum difference between actual (true) [Average output power \(optical\)](#) and the nominal (selected) average output power.

Conditions: After modulator auto bias (“modulator optimization”) performed with the selected wavelength. Other conditions as specified.

Measurement: Using an average power meter with averaging time set to 1 s.

Average power measurement uncertainty (optical)

Maximum difference between measured average (over time) optical power and true average optical power at the LCA optical input.

Measurement: Comparison with an average power meter with averaging time set to 1 s.

Average power measurement range (optical)

The range for the average optical power where the specification for [Average power measurement uncertainty \(optical\)](#) applies.

Decibel (dBm, dBo, dBe)

A ratio in decibel (dB) is calculated as $10 \cdot \log_{10}\{\text{ratio}\}$.
Special cases:

- dBo: specifically the ratio of optical powers (‘o’ for ‘optical’).
- dBe: specifically the ratio of electrical powers (‘e’ for ‘electrical’).
- dBm: power level related to 1 mW (electrical or optical).

NOTE

Differences of powers in dBm are written as “dBo” for optical powers or “dBe” for electrical powers.

Definition of Terms

- $\text{dB}_{A/W}$: the square of the **Responsivity** R divided by $1/A/W$,

$$10\log_{10}\left\{\left(\frac{R}{1A/W}\right)^2\right\}$$

or

$$20\log_{10}\left\{\frac{R}{1A/W}\right\}$$

- $\text{dB}_{W/A}$ is defined correspondingly to $\text{dB}_{A/W}$.

NOTE

Differences of responsivities in $\text{dB}_{A/W}$ or $\text{dB}_{W/A}$ are written as “dBe”.

NOTE

For O/E and E/O converters with linear relation between optical power and electrical current, optical ratios in dBo have half the magnitude of the electrical ratios in dBe.

Electrical loss of optical test set

The electrical (RF) signal loss of the optical test set between Network Analyzer electrical port and LCA electrical port. LCA set to E/E mode.



Conditions: Frequency range as specified.

Frequency response repeatability

In repeated measurements of the (absolute) frequency response under constant conditions, the repeatability $\pm Rep$ at each modulation frequency is defined as twice the standard deviation, $StDev_i$, of the measured responsivities R_i over the repetitions i :

$$Rep = 2 \times StDev_i\{R_i\}$$

Conditions: fixed cables and unchanged connections. Other conditions as specified.

Measurement: using a stable DUT.

Maximum linear average input power (optical)

The maximum average optical input power at the LCA optical input for which the system specifications apply.

Conditions: as specified.

Maximum safe average input power (optical)

Maximum optical power that can be applied to the LCA optical input without permanent change of the LCA's characteristics.

CAUTION

Applying more than the specified maximum safe input power may damage the LCA!

Minimum measurable frequency response (noise floor)

The average of the [Responsivity](#) measured by the LCA on a DUT with zero output, expressed in [Decibel \(dBm, dBo, dBe\)](#). The value is calculated by averaging the measured responsivity in linear space (rather than decibel space) over the modulation frequency within a specified modulation frequency range.

Conditions: As specified.

NOTE

Responsivity values are converted from [Decibel \(dBm, dBo, dBe\)](#) values to linear values by: $linear = 10^{\text{decibel}/20}$. The average is converted back to decibels by: $decibel = 20 * \log_{10}(linear)$.

Modulated optical power

The amplitude of a harmonic optical power modulation. The modulated optical power is calculated from the peak optical power P_{\max} and the average optical power P_{avg} ,

in Watts: $P_{\text{mod}} = P_{\max} - P_{\text{avg}}$

in dBm: $P_{\text{mod,dB}} = 10\text{-log}(P_{\text{mod}} / 1\text{mW})$.

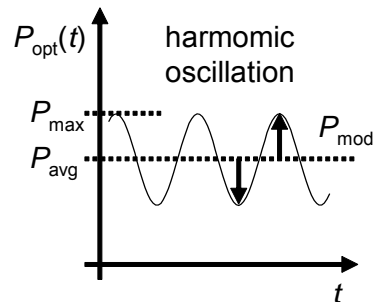

NOTE

Modulated optical power divided by average optical power is a value between 0 (no modulation) and 1 (full modulation). See also [OMI \(optical modulation index\)](#).

NOTE

For full modulation, modulated optical power equals average optical power.

Operating frequency range (optical test set)

The modulation frequency range for which the LCA optical test set (including optical transmitter and receiver) is designed to supply give measurement results.

OMI (optical modulation index)

Specifies the [Modulated optical power](#) divided by [Average output power \(optical\)](#).

Condition: modulation frequency as specified.

NOTE

OMI is a value between 0% (no modulation) and 100% (full modulation).

Operating input wavelength range

The wavelength range on the LCA optical input for which the LCA system is designed.

Optical return loss (LCA optical input)

Ratio between incident optical power at LCA optical input and reflected optical power, expressed in dBo.

Output wavelength

Center of gravity wavelength of the signal at LCA optical output. Wavelength is defined as wavelength in vacuum.

Relative frequency response uncertainty

When taking the difference between measured [Responsivity](#) of a device under test and actual (true) responsivity in dBe over modulation frequency, the system relative frequency response uncertainty is \pm half the peak-to-peak difference.

Conditions: Modulation frequency range as specified. Other conditions as specified.

NOTE

Changes in the cabling after user e-cal add to the specified relative frequency response uncertainty.

Measurement: Based on a reference RF O/E receiver.

Responsivity

The amplitude response R of a device under test (DUT) to a harmonic stimulus:

- E/O measurement: R is the ratio of [Modulated optical power](#) in Watt to the electrical stimulus amplitude in Ampere, expressed in W/A.
- O/E measurement: R is the ratio of electrical response amplitude in Ampere to the [Modulated optical power](#) in Watt, expressed in A/W.

In both cases, responsivity in [Decibel \(dBm, dBo, dBe\)](#) (“dB_{W/A}” or “dB_{A/W}”) is calculated as $20 \cdot \log(R)$.

Definition of Terms

- O/O measurement: R is the difference between the **Modulated optical power** in dBm at the DUT output and at the DUT input, expressed in dBo. If expressed in dBe, it is twice this number.

NOTE

Responsivity of an O/E or E/O device may be called *conversion efficiency*. For an O/O device, R [dBo] = -(insertion loss [dB]).

References

- (1) “Guide to the Expression of Uncertainty in Measurement” (“GUM”), BIPM, IEC, ISO et al. (1993)

11

Specifications

Definitions	136
Transmitter and Receiver Specifications	140
General Characteristics	145

Definitions

Generally, all specifications are valid at the stated operating and measurement conditions and settings, with uninterrupted line voltage.

Specifications (guaranteed)

Describes warranted product performance that is valid under the specified conditions.

Specifications include guard bands to account for the expected statistical performance distribution, measurement uncertainties changes in performance due to environmental changes and aging of components.

Typical Values (characteristics)

Characteristics describe the product performance that is usually met but not guaranteed. Typical values are based on data from a representative set of instruments.

General Characteristics

Give additional information for using the instrument. These are general descriptive terms that do not imply a level of performance.

Explanation of Terms

Responsivity

For electro-optical devices (e.g. modulators) this describes the ratio of the optical modulated output signal amplitude compared to the RF input amplitude of the device.

For opto-electrical devices (e.g. photodiodes) this describes the ratio of the RF amplitude at the device output to the amplitude of the modulated optical signal input.

Relative Frequency Response Uncertainty

Describes the maximum deviation of the shape of a measured trace from the (unknown) real trace. This specification has strong influence on the accuracy of the 3 dB cut-off frequency determined for the device under test.

Absolute Frequency Response Uncertainty

Describes the maximum difference between any amplitude point of the measured trace and the (unknown) real value. This specification is useful to determine the absolute responsivity of the device versus modulation frequency.

Frequency Response Repeatability

Describes the deviation of repeated measurement without changing any parameter or connection relative to the average of this measurements.

Minimum Measurable Frequency Response

Describes the average measured responsivity when no modulation signal is present at the device under test. This represents the noise floor of the measurement system.

Definition of LCA Input and Output Names

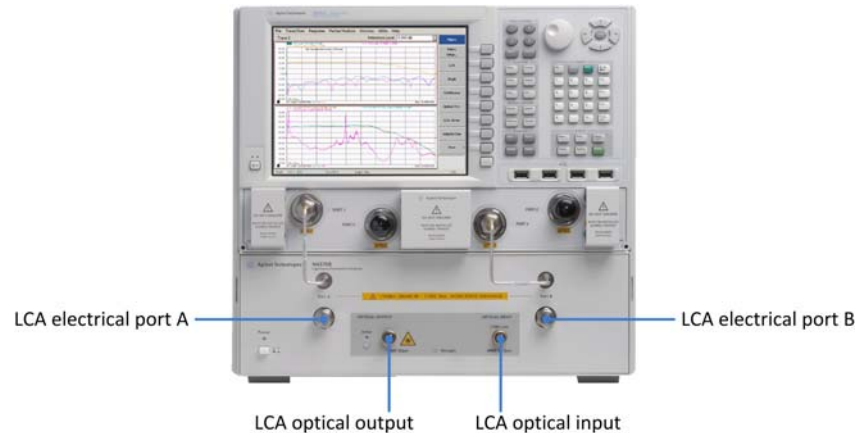

Agilent N4376D Specifications

Measurement conditions:

- Modulation frequency range from 10 MHz to 26.5 GHz
- Forward RF power +3 dBm
- Reverse RF power 0 dBm
- Number of averages: 1
- 100 Hz IFBW (“Reduce IF bandwidth at low frequency” enabled) with modulation frequency step size 10 MHz and measurement points on a 10 MHz raster (if not differently stated)
- Network analyzer set to “stepped sweep – sweep moves in discrete steps”
- All network-analyzer ports configured in standard coupler configuration (“CPLR ARM” to “RCVB B in”, “SOURCE OUT” to “CPLR THRU”)
- After full two-port electrical calibration using an Electronic Calibration Module, Agilent N4691B, at constant temperature (± 1 °C) with network analyzer set to -10 dBm electrical output power
- Modulator bias optimization set to “continuous sweep”
- Measurement frequency grid equals electrical calibration grid

- DUT signal delay $\leq 0.1/\text{IF-BW}$
- Specified temperature range: +20 °C to +26 °C
- After warm-up time of 90 minutes
- Using high quality electrical and optical connectors and RF cables in perfect condition
- 50 μm FC/APC to FC/PC patchcord at the input and output
- Launched power distribution according to IEEE 802.3ae - 2002, according to the diagram

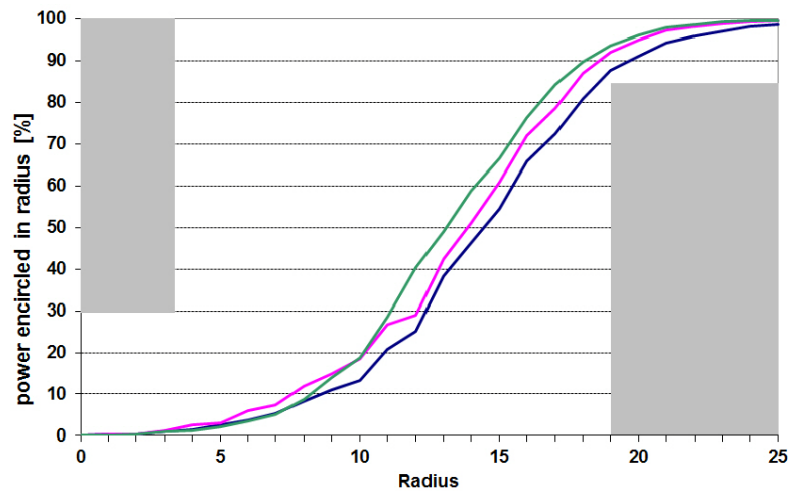

- Test performed using an optical reference source with return loss better 45 dB, spectral width FWHM < 10 MHz and InGaAs detector
- The optical test set always has angled connectors. Depending on the selected option (-023, -024, -025, -026) the appropriate jumper cable will be delivered. This jumper cable must always be used in front to the optical test set to protect the connectors at the optical test set and is required for performance tests.

Transmitter and Receiver Specifications

Optical test set		
Operation frequency range	10 MHz to 26.5 GHz	
Connector type (optical test set)	Optical input:	62.5 μ m MMF angled with Agilent versatile connector interface
	Optical output:	50 μ m MMF angled with Agilent versatile connector interface
	RF	3.5 mm male
LCA optical input		
Operating input wavelength range	750 nm to 1650 nm	
Maximum linear average input power ^a	Optical input: -1 dBm	
Maximum safe average input power	Optical input: +3 dBm	
Optical return loss (typical) ^a	>14 dBo	
Average power measurement range ^a	-25 dBm to -1 dBm	
Average power measurement uncertainty (typical) ^a	± 0.7 dBo	
LCA optical output		
Optical modulation index (OMI) at 10 GHz (typical)	25 % at +3 dBm RF (typical) 31 % at +5 dBm RF (typical)	
Output wavelength	(850 \pm 10) nm	
Launched power distribution (typical)	According to IEEE 802.3ae - 2002	
Average output power range	-5 dBm to -1 dBm	
Average output power uncertainty (typical) ^b	± 0.7 dBo	
Average output power stability 15 minutes (typical)	± 0.5 dBo	

^a Wavelength within range as specified for LCA optical output

^b After modulator optimization

Specifications for Electrical-Electrical Measurements (E/E Mode)

All specifications of the N5222A option 200, 201, 219, 400, 401, or 419 network analyzer apply depending on selected LCA option -x2z. Please see the corresponding network analyzer data sheet and user's guide.

Optical test set	
Electrical loss of optical test set	< 2.0 dBe (typical)

Specifications for Electro-Optical Measurements at 850 nm (E/O Mode)

N4376D system with network analyzer:

- N5222A-200, N5222A-201, N5222A-219
- N5222A-400, N5222A-401, N5222A-419

Specifications are valid under the stated measurement conditions.

- For wavelength: (850 ± 10) nm

System performance		0.05 GHz to 0.2 GHz	0.2 GHz to 10 GHz	10 GHz to 20 GHz	20 GHz to 26.5 GHz
Relative frequency response uncertainty	DUT response ≥ -26 dB(W/A) ^a	± 1.0 dBe typical	± 1.3 dBe (± 0.9 dBe typical)	± 1.5 dBe (± 1.0 dBe typical)	± 1.0 dBe typical
	≥ -36 dB (W/A)	± 1.0 dBe typical	± 0.9 dBe typical	± 1.0 dBe typical	± 1.2 dBe typical
	≥ -46 dB (W/A)	± 1.1 dBe typical	± 0.9 dBe typical	± 1.3 dBe typical	± 2.0 dBe typical
Absolute frequency response uncertainty (typical)	DUT response ≥ -26 dB (W/A) ^a	± 2.1 dBe	± 2.0 dBe	± 2.0 dBe	± 2.4 dBe typical
Frequency response repeatability (typical)	DUT response ≥ -26 dB (W/A) ^a	± 0.1 dBe	± 0.1 dBe	± 0.1 dBe	± 0.1 dBe typical
	≥ -36 dB (W/A)	± 0.15 dBe	± 0.1 dBe	± 0.15 dBe	± 0.25 dBe typical
Minimum measurable frequency Response (noise floor) ^{b c}		-65 dB (W/A)	-82 dB (W/A)	-69 dB (W/A)	-69 dB (W/A) typical

^a For DUT response max. $\leq +0$ dBm.

^b IFBW = 10 Hz.

^c Note: average value over frequency range.

Specifications for Optical-Electrical Measurements at 850 nm (O/E Mode)

N4376D system with network analyzer:

- N5222A-200, N5222A-201, N5222A-219
- N5222A-400, N5222A-401, N5222A-419

Specifications are valid under the stated measurement conditions.

- For wavelength: (850 ± 10) nm

System performance		0.05 GHz to 0.2 GHz	0.2 GHz to 10 GHz	10 GHz to 20 GHz	20 GHz to 26.5 GHz
Relative frequency response uncertainty	DUT response ≥ -21 dB (A/W) ^a	± 1.0 dBe typical	± 1.3 dBe (± 0.9 dBe typical)	± 1.5 dBe (± 1.0 dBe typical)	± 1.0 dBe typical
	≥ -31 dB (A/W)	± 1.0 dBe typical	± 0.9 dBe typical	± 1.1 dBe typical	± 1.2 dBe typical
	≥ -41 dB (A/W)	± 1.2 dBe typical	± 0.9 dBe typical	± 1.5 dBe typical	± 1.2 dBe typical
Absolute frequency response uncertainty (typical)	DUT response ≥ -21 dB (A/W) ^a	± 1.9 dBe	± 1.7 dBe	± 1.8 dBe	± 2.0 dBe typical
Frequency response repeatability (typical)	DUT response ≥ -21 dB (A/W) ^a	± 0.25 dBe	± 0.1 dBe	± 0.2 dBe	± 0.25 dBe typical
	≥ -31 dB (A/W)	± 0.3 dBe	± 0.1 dBe	± 0.25 dBe	± 0.5 dBe typical
Minimum measurable frequency Response (noise floor) ^{b c}		-58 dB (A/W)	-77 dB (A/W)	-68 dB (A/W)	-68 dB (A/W) typical

^a For DUT response max. +15 dB (A/W).

^b IFBW = 10 Hz.

^c Note: average value over frequency range.

Specifications for optical to optical measurements at 850 nm (0/0 mode)

N4376D system with network analyzer:

- N5222A-200, N5222A-201, N5222A-219
- N5222A-400, N5222A-401, N5222A-419

Specifications are valid under the stated measurement conditions.

- For wavelength (850 ±10) nm

System performance		0.05 GHz to 0.2 GHz	0.2 GHz to 10 GHz	10 GHz to 20 GHz	20 GHz to 26.5 GHz
Relative frequency response uncertainty	DUT response ≥ -10 dBe ^{a b} (≥ -5.0 dBo)	±0.5 dBe (±0.25 dBo typical)	±0.4 dBe (±0.2 dBo)	±0.5 dBe (±0.25 dBo)	±0.5 dBe typical (±0.25 dBo typical)
Absolute frequency response uncertainty (typical)	DUT response ≥ -10 dBe ^{a b} (≥ -5.0 dBo)	±1.1 dBe	±1.0 dBe	±1.0 dBe	±1.0 dBe typical
Frequency response repeatability (typical) ^a	DUT response ≥ -10 dBe ^{a b} (≥ -5.0 dBo)	±0.15 dBe	±0.1 dBe	±0.15 dBe	±0.15 dBe typical
Minimum measurable frequency Response (noise floor) ^{b c d}		-53 dBe (-26.5 dBo)	-70 dBe (-35 dBo)	-44 dBe (-22 dBo)	-44 dBe typical (-22 dBo typical)

^a For DUT response max. 0 dB.

^b Average output power from LCA optical output set to -1 dBm.

^c IFBW = 10 Hz.

^d Note: average value over frequency range.

General Characteristics

Assembled dimensions (H x W x D)	
Max, 413 mm x 438 mm x 538 mm (16.3 in x 17.3 in x 21.2 in)	
Weight	
Product net weight: 38 kg (81.6 lbs) to 52 kg (114.6 lbs) depending on selected NWA	
Packaged product: 56 kg (123.5 lbs) to 54 kg (119 lbs) depending on selected NWA	
Power requirements	
100 to 240 V~, 50 to 60 Hz (2 power cables)	
N5222A	Max. 450 VA
Optical test set	Max. 40 VA
Storage temperature range	
-40 °C to +70 °C	
Operating temperature range	
+5 °C to +32 °C	
Humidity	
15% to 80% relative humidity, non-condensing	
Altitude (operating)	
0 ... 2000 m	
Recommended recalibration period	
1 year	

General Characteristics (continued)

Shipping contents	
1x network-analyzer depending on selected option	
1x N4376D optical test set	
2x 81000 NI optical adapter	
1x 4376D-90A01 Getting Started Guide	
1x N4373-61627 f 3.5 mm to f 3.5 mm RF short cut cable	
1x 4373B-90CD1 LCA support CD	
1x 1150-7896 keyboard	
1x 1150-7799 mouse	
1x 8121-1242 USB cable	
1x E5525-10285 UK6 report	
1x 9320-6677 RoHS addendum for photonic T&M accessories	
1x 9320-6654 RoHS addendum for photonic T&M products	
Additional, option dependent shipping contents	
-023	2x LC 50 μ m to FC/APC 0.5 m patch cord, feedthrough
-024	2x LC 62.5 μ m to FC/APC 0.5 m patch cord, feedthrough
-025	2x SC 50 μ m to FC/APC 0.5 m patch cord, feedthrough
-026	2x SC 62.5 μ m to FC/APC 0.5 m patch cord, feedthrough
-2yz 2-port network analyzer	1x N4373-61604 0.5 m (m) to (f) high performance RF cable
-2yz 4-port network analyzer	2x N4373-61604 0.5 m (m) to (f) high performance RF cable

LCA connector types ^a	
Optical test set	
LCA port A	3.5 mm (m)
LCA port B	3.5 mm (m)
LCA optical input	62.5 μm single-mode angled ^a , with Agilent universal adapter
LCA optical output	50 μm single-mode angled ^a , with Agilent universal adapter
Laser safety information	
	<p>All laser sources listed above are classified as Class 1M according to IEC 60825-1/2007.</p> <p>All laser sources comply with 21 CFR 1040.10 except for deviations pursuant to Laser Notice No. 50, dated 2007-06-24.</p>

^a The optical test set always has angled connectors. For input and output, a 50 μm or 62.5 μm angled to straight LC or SC patchcord must be selected. The connection to the DUT is always either LC or SC straight. The jumper cable must always be used in front of the optical test set to protect the connectors of the optical test set.

For 2-port PNA (Options 22x):

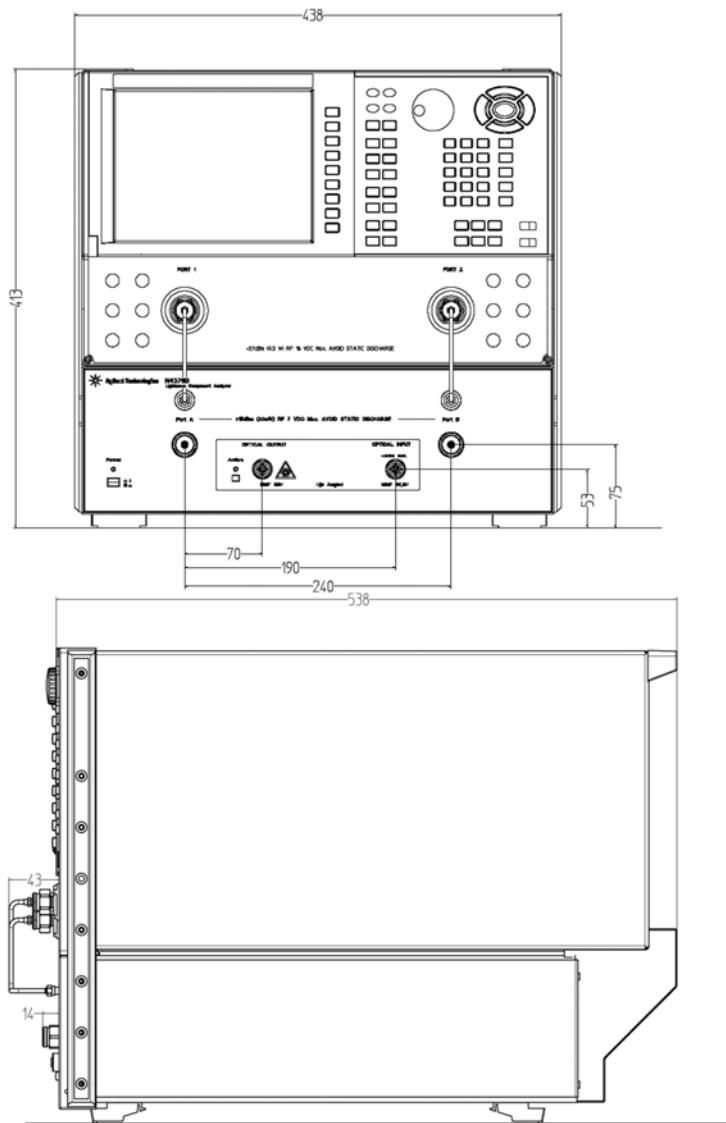

For 4-port PNA (Options 42x):

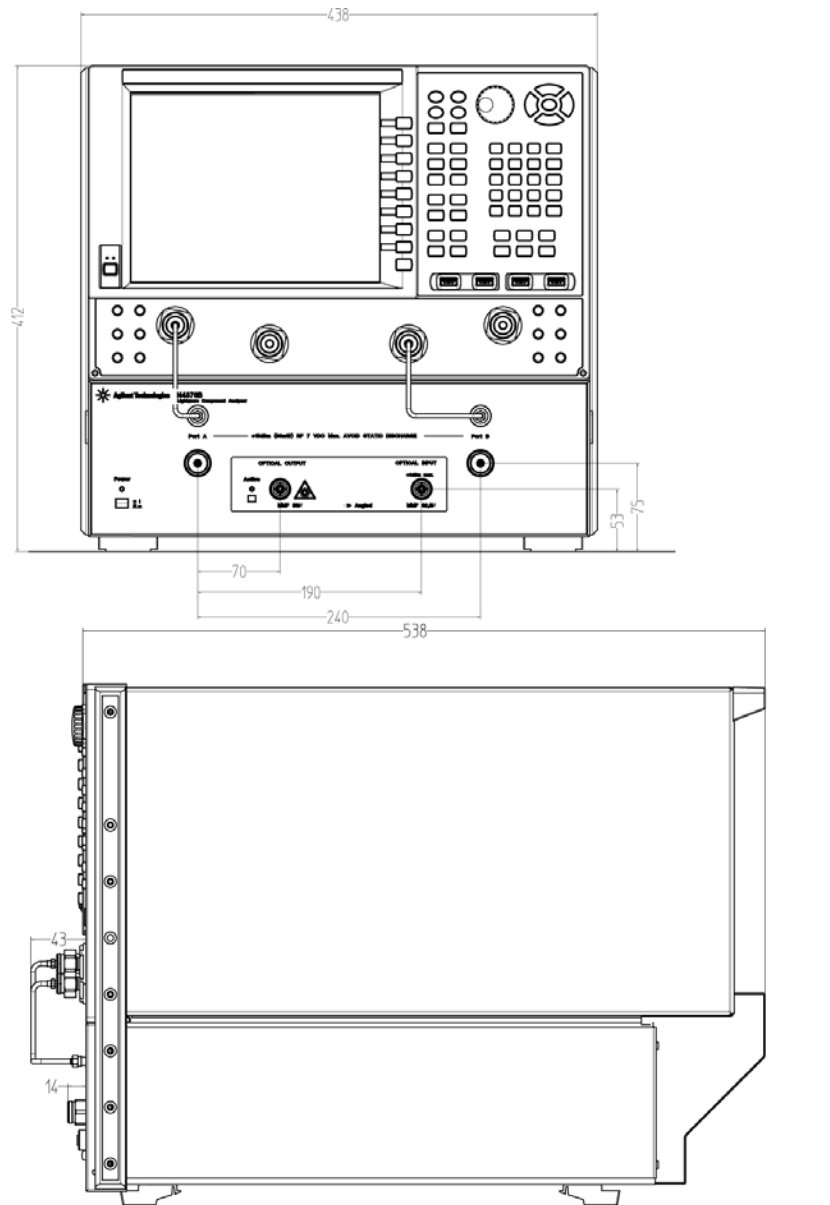

Specifications

12

Regulatory and Warranty Information

Regulatory Information	152
Declaration of Conformity.....	153
Warranty	154

Regulatory Information

- Compliance with Canadian EMC Requirements
This ISM device complies with Canadian ICES-001.
Cet appareil ISM est conforme à la norme NMB-001 du Canada.

Table 1 Notice for Germany: Noise Declaration

Acoustic Noise Emission
LpA < 50 dB
Operator position
Normal operation
per ISO 7779

Power	AC 100 to 240 V \pm 10%, 50 to 60 Hz, 120 VA max.
Environmental	
<i>Storage temperature</i>	-40° C to +70° C
<i>Operating temperature</i>	5° C to +35° C
<i>Humidity</i>	15% to 80% non-condensing
Dimensions	430 mm x 470 mm x 145 mm
Weight	net 4.200 kg (9.3 lbs); shipping 8.4 kg (14.5 lbs)
Maximum operating altitude	2000 m

Declaration of Conformity

 Agilent Technologies	DECLARATION OF CONFORMITY According to EN ISO/IEC 17050-1:2004	
---	--	---

Manufacturer's Name: Agilent Technologies Singapore (International) Pte. Ltd.
Manufacturer's Address: No. 1 Yishun Ave 7
 SINGAPORE 768923
 Singapore

Declares under sole responsibility that the product as originally delivered

Product Name: Lightwave Component Analyzer
Product Number:

N4373B	67 GHz 1550nm
N4373C	67 GHz 1310/1550nm
N4373D	67 GHz 1310/1550nm
N4374B	4.5 GHz 1310/1550nm
N4375B	20/26.5 GHz 1310/1550nm
N4375D	26.5 GHz 1310/1550nm
N4376B	20/26.5 GHz 850 nm
N4376D	26.5 GHz 850 nm

Product Options: *This declaration covers all options of the above system.*

complies with the essential requirements of the following applicable European Directives, and carries the CE marking accordingly:

- The Low Voltage Directive 2006/95/EC
- The EMC Directive 2004/108/EC

and conforms with the following product standards:

EMC	Standard	Limit
	IEC 61326-1:2005 / EN 61326-1:2006	
	<i>Reference Standards</i>	
	CISPR 11:2003 / EN 55011:1998+A1:1999+A2 :2002	Group 1 Class A
	IEC 61000-4-2: 2001 / EN 61000-4-2:1995+A1:1998+A2:2001	4 kV CD, 4 kV AD
	IEC 61000-4-3:2002+A1:2002 / EN 61000-4-3:2002+A1:2002	3 V/m / 80 MHz-2 GHz, 1V/m / 2-2.7 GHz
	IEC 61000-4-4:2004 / EN 61000-4-4:2004	0.5 kV signal lines, 1 kV power lines
	IEC 61000-4-5: 2001 / EN 61000-4-5:1995+A1:2001	0.5 kV line-line, 1 kV line-ground
	IEC 61000-4-6:2003 / EN 61000-4-6:1996+A1:2001	3 V, 0.15-80 MHz
	IEC 61000-4-11:2004 / EN 61000-4-11:2004	0% for 1/0.5 (0°, 180°) cycle 0% for 250/300 cycles 70% for 25/30 cycles
	Canada: ICES/NMB-001:2004	
	Australia/New Zealand: AS/NZS CISPR 11:2004	
Safety	IEC 61010-1:2001 / EN 61010-1:2001	
	IEC 60825-1:2007 / EN 60825-1:2007	
	Canada: CAN/CSA-C22.2 No. 61010-1:2004	
	USA: UL 61010-1:2004; FDA 21CFR1040.10+Laser Notice No. 50	

Supplementary Information:

FDA Accession Number 9521220

The products were tested in a typical configuration with Agilent Technologies test systems.

This DoC applies to above-listed products placed on the EU market after:

2012-October-02

Date

 Hans-Martin Fischer
 Name

Product Quality & Compliance

Title

For further information, please contact your local Agilent Technologies sales office, agent or distributor, or Agilent Technologies Deutschland GmbH, Herrenberger Straße 130, 71034 Boeblingen, Germany.

Template:A5971-5302-2, Rev. F.00

Year of first marking: 2007

Revision: F

Warranty

All system warranties and support agreements are dependent upon the integrity of the Agilent N4376D Lightwave Component Analyzer. Any modification of the system software or hardware will terminate any obligation that Agilent Technologies may have to the purchaser. Please contact your local Agilent field engineer before embarking in any changes to the system.

System

The warranty included in the sales price provides the following:

- All parts and labor necessary to return an instrument to full specified performance
- Factory-trained engineers perform all work using genuine Agilent parts
- Automated diagnostic tools ensure fast fault detection and resolution
- Repairs include relevant service notes and firmware updates
- Post-repair process includes performance testing, adjustments and calibration (operational verification in most Asian countries)
- In addition to the three-year warranty, extended warranty periods, on-site troubleshooting, reduced response times and increased coverage hours can be negotiated under a separate support agreement and will be charged at an extra cost.

Remove all doubt

Agilent offers a wide range of additional expert test and measurement services for your equipment, including initial start-up assistance onsite education and training, as well as design, system integration, and project management.

Our repair and calibration services will get your equipment back to you, performing like new, when promised. You will get full value out of your Agilent equipment throughout its lifetime. Your equipment will be serviced by Agilent-trained technicians using the latest factory calibration procedures, automated repair diagnostics and genuine parts. You will always have the utmost confidence in your measurements.

For more information on repair and calibration services, go to

www.agilent.com/find/removealldoubt



Agilent E-mail Updates

Get the latest information on the products and applications you select.

www.agilent.com/find/emailupdates



Agilent Direct

Quickly choose and use your test equipment solutions with confidence.

www.agilent.com/find/agilentdirect



Agilent Open

Agilent Open simplifies the process of connecting and programming test systems to help engineers design, validate and manufacture electronic products. Agilent offers open connectivity for a broad range of systemready instruments, open industry software, PC-standard I/O and global support, which are combined to more easily integrate test system development.

www.agilent.com/find/open

Phone or Fax

United States: (tel) 800 829 4444
(fax) 800 829 4433

Canada: (tel) 877 894 4414
(fax) 800 746 4866

China: (tel) 800 810 0189
(fax) 800 820 2816

Europe: (tel) 31 20 547 2111

Japan: (tel) (81) 426 56 7832
(fax) (81) 426 56 7840

Korea: (tel) (080) 769 0800
(fax) (080) 769 0900

Latin America: (tel) (305) 269 7500

Taiwan: (tel) 0800 047 866
(fax) 0800 286 331

Other Asia Pacific Countries: (tel) (65) 6375 8100
(fax) (65) 6755 0042

Email: tm_ap@agilent.com

Agilent Online Information:

<http://www.agilent.com/find/LCA>

Agilent photonic discussion forum

http://www.agilent.com/photonic_forum

For Network analyzer related literature, please visit:

Agilent Network Analyzers: www.agilent.com/find/na

Mechanical and Electronic Calibration Kits:

www.agilent.com/find/ecal

RF Test Accessories, Cabinets, Cables:

www.agilent.com/find/accessories or visit
www.agilent.com/find/mta for RF & Microwave Test
Accessories

Regulatory and Warranty Information

13

Ordering Information

Ordering Information

Agilent N4376D ordering options	
Wavelength Options	
N4376D-103	850 nm source optical test set
Network Analyzer Options	
N4376D-220	26.5 GHz, 2 ports, single source PNA (N5222A-200) and RF cables
N4376D-221	26.5 GHz, 2 ports, single source PNA (N5222A-201) with configurable test set and RF cables
N4376D-222	26.5 GHz, 2 ports, single source PNA (N5222A-219) with configurable test set, extended power range, bias-tees and RF cables
N4376D-420	26.5 GHz, 4 ports, dual source PNA (N5222A-400) and RF cables
N4376D-421	26.5 GHz, 4 ports, dual source PNA (N5222A-401) with configurable test set and RF cables
N4376D-422	26.5 GHz, 4 ports, dual source PNA (N5222A-419) with configurable test set, extended power range, bias-tees and RF cables
N4376D-229	Integration of customer's 26.5 GHz, 2 port PNA (N5222A or N5242A) with any configuration and RF cables ^a
N4376D-249	Integration of customer's 26.5 GHz, 4 port PNA (N5222A or N5242A) with any configuration and RF cables ^a
Software options^{b, c}	
N4376D-S10	Time-domain measurements
Connector options	
N4376D-023	LC 50 μ m connector interface (external 0.75 m patch cord)
N4376D-024	LC 62.5 μ m connector interface (external 0.75 m patch cord)
N4376D-025	SC 50 μ m connector interface (external 0.75 m patch cord)
N4376D-026	SC 62.5 μ m connector interface (external 0.75 m patch cord)
Testset options	
N4376D-050	External optical input

^a Guaranteed specification applies only for the above mentioned network analyzer options.

^b For detailed ordering requirements for software options please refer to the LCA configuration guide.

^c Other network analyzer software options can be added through network analyzer upgrades N522xAU-xyz. To be ordered separately.

Recommended accessories	
Rack mount kit for network analyzer	Description
5063-9217	Rack mount flange kit - 265.9 mm height for installation without handles
E3663AC	Basic rail kit (for system II instruments)

Power Cords

Power Cords		
8164B-900	United Kingdom	8120-1351
8164B-901	Australia & New Zealand	8120-4419
8164B-902	Continental Europe	8120-1689
8164B-903	United States (120 V)	8120-1378
8164B-906	Switzerland	8120-2104
8164B-912	Denmark	8120-3997
8164B-917	Republic of South Africa and India	8120-4211
8164B-918	Japan	8120-4753
8164B-919	Israel	8120-5182
8164B-922	China	8120-8376
8164B-927	Brazil and Thailand	8120-8871

Ordering Information

Index

.s2p data file 66

A

advanced parameters 60

angled connectors 26
return loss 28

application

reinstalling 125
starting 72
updating 124

averaging 73

B

backing up 124

C

cabinet

installing in 11

caution

meaning 9

CE mark 10

cleaning 104

connector interfaces 113
equipment 105
fiber adapters 114
instrument housing 111
lenses 114
optical connectors 111
safety 10, 104

concept 42

conditions

for use 10

connector interfaces

cleaning 113

connectors

protecting 110

CSA mark 10

c-tick mark 10

D

data

backing up 124

deembedding

optical path 65
RF path 66

default parameters 60

disposal 15

E

earth, see protective earth

EE measurement 94

electrical calibration

performing 76
troubleshooting 34
verifying 33

electrical measurement 94

electrical ports 17, 19, 21

electro-optical, see EO

EO measurement 90

initializing 91
making (single-ended) 93, 94
theory of operation 44

event log 122

F

fiber adapters

cleaning 114

frequency dependent interference 28

front panel 16, 19

function keys 18, 21, 58

fuse 22

replacing 119

G

ground, see protective earth

I

input 1 63, 68

installing 26

in cabinet 11

power switch 11

reinstalling 124

instruction manual symbol 10

instrument housing

cleaning 111

interference

frequency dependent 28

L

laser

enabling and disabling 28

on 63, 68

radiation symbol 10

safety 13

source class 12

switch 17, 20

LCA application

starting 72

LCA server

restarting 126

LCA system settings 63

lenses

cleaning 114

lifting 26

lightwave component analyzer, see LCA

line power, see power

M

measure mode 62

modulator auto bias 64, 68

N

network analyzer

documentation 8

ports 21

O

O/E measurement

balanced 89

OE measurement 81

initializing 82

making (single-ended) 89

theory of operation 45

off-on symbol 10

OO measurement 95

initializing 96

making (single-ended) 101

specification 144

theory of operation 45

operation

theory 42

troubleshooting 36, 122

verifying 34

optical connectors

cleaning 111

ports

optical 17, 20

optical input 17, 20, 63, 68

specifications 140

optical output 17, 20

specifications 140

optical path deembedding 65

optical port 17, 20

angled connectors 26

protecting 26

optical power

measuring 101

optical test set

specifications 140

optical-optical, see OO

Index

opto-electrical, see OE
ordering options 160
overvoltage category 11

P

performance
 troubleshooting 39
 verifying 37
pollution degree 11
Port A 17, 19
Port B 18, 20
ports
 electrical 17, 19
power 63, 68
 cable 13, 161
 cable connector 22
 consumption 13
 cord 11
 fuse 22
 measuring optical 101
 switch 17, 19
protective earth 10, 14

R

radiation exposure 11
rear panel 22
recycling 15
 symbol 10

reinstalling 124
return loss
 angled connectors 28
RF path deembedding 66
RF port, see electrical port
ripple 28

S

s/n ratio 73
safety class 10
serviceable parts 10
setting up, see installing
shipment
 contents 24
 network analyzer 25
smoothing 73
software
 reinstalling 124
s-parameter
 theory 46
stepped sweep 72
sweep setup 72
symbols 10

T

theory of operation 42
Touchstone data file 66

troubleshooting
 electrical calibration 34
 event log 122
 operation 36, 122
 performance 39

U

unpacking 24
updating 124
USB connection 27
USB port 22
user calibration 63

V

ventilation 11
verifying
 electrical calibration 33
 operation 34
 performance 37
voltage range 11, 13

W

warning
 meaning 9
warranty 2, 154
wavelength 63, 68

www.agilent.com

© Agilent Technologies, Deutschland GmbH
2009 - 2013

First Edition, August 2013

4376D-90B01

